



DECEMBER 8-9, 14-23 | 4-10pm



VENDOR FAQs

WHO SHOULD PARTICIPATE?

We are looking for vendors with unique food, merchandise, and gift options that incorporate our festive holiday theme.

WHAT ARE THE EVENT DATES AND HOURS?

December 8-9, 14-23, 2023 from 4pm to 10pm.

DO VENDORS NEED TO PARTICIPATE ALL DAYS?

Yes, it is mandatory that all vendors participate all 12 days.

WHAT ARE THE OPERATIONAL HOURS?

Vendors must be fully operational by 3:45pm and open until 10pm. On opening day, December 8, vendors must be fully moved-in and set-up by 2pm.

WHAT HAPPENS IF THERE IS INCLEMENT WEATHER?

The team at the PNE assesses the weather conditions and will inform all vendors if there are any changes to the hours of operation.

WHEN IS PAYMENT DUE?

Upon acceptance, vendors must pay a booth deposit and send their signed contract. Failure to make this payment and send in the signed contract by November 10 will result in forfeiture of your booth space. Full booth payment is due November 10, 2023.

CAN I SHARE BOOTH SPACE WITH ANOTHER VENDOR?

No, vendors are not permitted to share their booth space with other vendors.

WHAT OTHER INFORMATION IS REQUIRED?

Vendors must provide \$2 Million Public Liability Insurance, WorkSafe BC registration number, and valid clearance letter by November 10, 2023.



DECEMBER 8-9, 14-23 | 4-10pm



VENDOR FAQs

WHEN IS THE APPLICATION DEADLINE?

November 10th, 2023. Applications received after this date are subject to availability.

CAN I GET ADDITIONAL ID PASSES?

Yes, please contact the Exhibit Space team to request additional passes.

WHERE WILL I BE PARKING?

Vendors will be provided with on-site parking.

For more information about the 2023 PNE Winter Fair please visit: www.pne.ca/winter-fair

For additional vendor information and to apply, please visit: www.pne.ca/fair-vendors

APPLY NOW

If you have any questions, please email exhibitsales@pne.ca



INDOOR MARKET VENDORS

We are offering different booth sizes to fit your needs. We want all vendors to have an opportunity to participate and have options to accommodate different budgets.

WHAT ARE MY BOOTH DIMENSIONS?

5x5 and 5x10 booths must exhibit only within their allotted space with a maximum height of 8ft.

Tabletop booths will be provided with a 6ft x 2.5ft table top space with a white table covering (there will be standing space and 8ft pipe and drape behind the table).

All tabletop vendors must limit the height of their table top display to 2ft. As this is a smaller more community style area, we ask that vendors are respectful of their neighbours.

CAN I ORDER ADDITIONAL ELECTRICAL?

Yes, please contact the [Exhibit Space](#) team to order additional electrical.

WHEN DO I NEED TO MOVE-IN?

Indoor vendor move in begins December 7 and must be moved in by December 8 at 2pm.

WHEN DO I NEED TO MOVE-OUT?

Indoor vendor move out begins at 10pm on December 23 and vendors must be fully moved out by midnight.

CLICK THE LINKS BELOW FOR INSPIRATION* ON HOW TO SET-UP YOUR BOOTH:

[5x5 Booth](#) » (external link)

[10x5 Booth](#) » (external link)

[Table Top Space](#) » (external link)

* *These are just ideas on how to set-up and style your booth, vendors must still adhere to their contracted booth dimensions*



DECEMBER 8-9, 14-23 | 4-10pm

OUTDOOR: POP-UP HOLIDAY MARKET HUT VENDORS

WHAT ARE THE DIMENSIONS OF THE HUT?

Approximately 9ft by 7ft. See image below for exact dimensions.

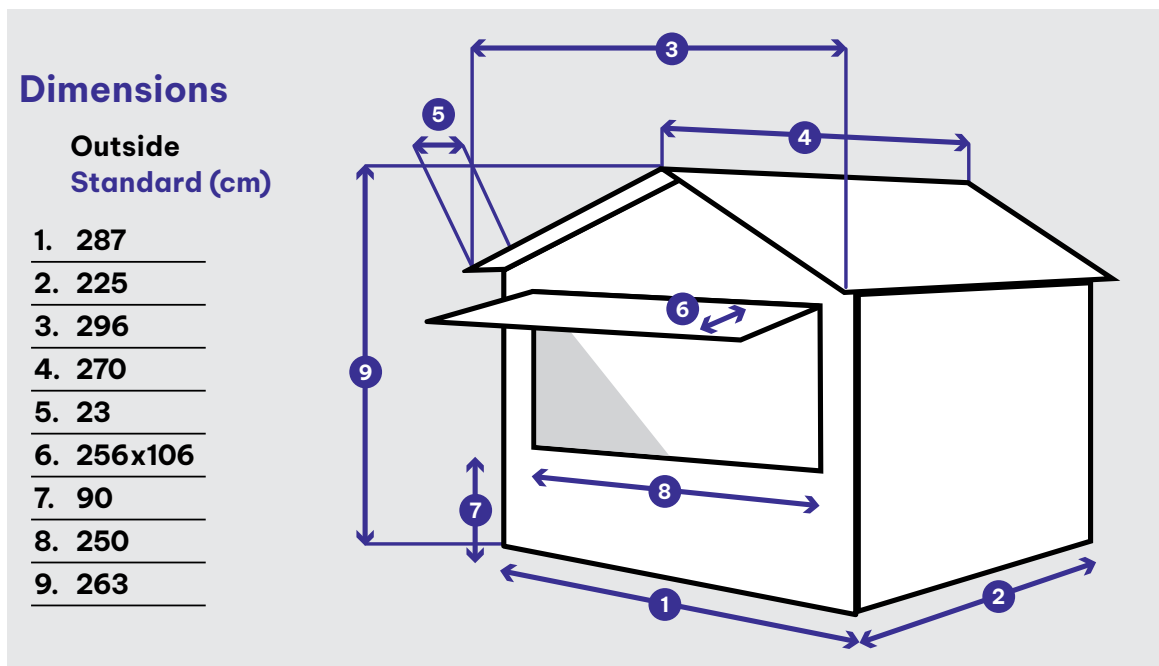

WHAT IS INCLUDED IN THE COST?

Your hut rental, a 15amp outlet, use of a PNE heater on its own dedicated outlet, 2 ID passes, and 2 on-site parking passes.

CAN I ORDER ADDITIONAL ELECTRICAL?

Yes, please contact the [Exhibit Space](#) team to order additional electrical.



DECEMBER 8-9, 14-23 | 4-10pm



OUTDOOR: POP-UP HOLIDAY MARKET HUT VENDORS

WHEN IS MOVE-IN?

Hut vendor move in begins December 7 and vendors must be moved in by December 8 at 2pm

WHEN IS MOVE-OUT?

Hut vendor move out begins at 10pm on December 23 and vendors must be fully moved out by midnight.

HOW CAN I SET UP MY BOOTH?

We allow one rectangular table that must run parallel against the front of the hut (beneath the awning). This table must be covered by a tablecloth and can be up to 96x30 inches.

- Vendors must provide their own lock.
- Drilling and nailing directly onto the Vendor Hut is not permitted.
- Removable utility hooks (ie. Command hooks) must be used if you are fastening anything to the hut.
- Any damages incurred will be subject to a repair fee.



DECEMBER 8-9, 14-23 | 4-10pm



OUTDOOR: FOOD VENDORS

COST:

25% of Gross Sales plus \$27 C.A.F.E. Fee, non-refundable electrical & water/sewer connection fee: up to 60 amps is \$525 and over 60 amps is \$875 plus applicable taxes.

What is included in the cost: Truck space, electrical, water/sewer, 4 ID passes, and 2 on-site parking passes.

WILL I BE USING MY OWN POS TERMINAL?

No, you will receive a PNE-issued terminal to process payments. No cash sales are permitted. Vendors are required to pay an additional 1% processing fees. Vendors must pay a refundable \$425 POS terminal deposit. Payout dates are December 12, 19, 22, and 29.

CAN I MOVE MY TRUCK OFF-SITE ON DAYS THAT ARE CLOSED?

No. As vendors must be plumbed in and connected to our electrical utilities, vendors are required to keep their food truck on site from initial move-in until the end of the Winter Fair. Move-out begins after 10pm on December 23.

WHEN DO I NEED TO MOVE-IN?

Food Vendor move-in begins Monday, December 4. Vendors must be moved in by Wednesday, December 6. Vendors must be on-site for VCH inspections on December 7.

WHEN DO I NEED TO MOVE-OUT?

Food Vendors can move out after 10pm on December 23. The grounds will be closed from December 24-26. Vendors can resume moving out on December 27 and must be fully vacated by 4pm.

CAN I USE A TENT AS MY BOOTH SET-UP?

No, we do not allow the use of tents for outdoor food vendors.