

Amusement Park **PHYSICS**



PLAYLAND

**PHYSICS and
SCIENCE DAY
2026**

.....
Science 10

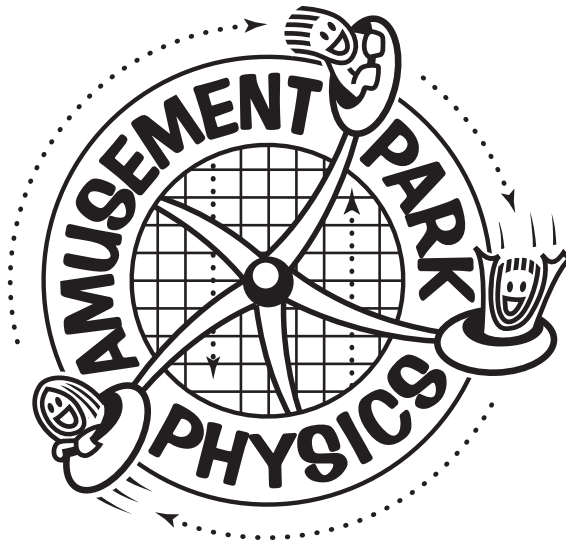

These educational materials were created by *Science Plus*.
For more information on Amusement Park Science
contact Steve Simms
simms_s@surreyschools.ca

Illustrations and graphic design by *Robert Browne Graphics*
Email: rbgraphics@telus.net • Tel: 604-460-2804

Vancouver, B.C., Canada
April 2026

Materials in this package are under copyright with James Wiese and Science Plus.
Permission is hereby given to duplicate this material for your use and for the use of
your students, providing that credit to the author is given.

Amusement Park Physics

and the new Secondary School Curriculum

Over the past few years, the educational system has seen a shift in the science curriculum and changes to how that curriculum is delivered. The current curriculum is more inquiry based with a focus on questioning, predicting, communication, planning and conducting investigations. In addition, students are asked to analyse not only the data they collect, but also the process that was used to collect the data.

The curriculum for Science has changed. Although some of the topics may not be in the curriculum for a certain course, inquiry and investigation are at the forefront. ***Amusement Park Physics*** can now be applied to any number of classes as they all include an inquiry / investigative component. Teachers are able to adapt or enhance the curriculum packages currently supplied by ***Amusement Park Physics*** as they see fit. This gives you, as an educator, tremendous flexibility in terms of how you and your class spend your time at Playland. You could focus on one ride and do an in-depth study or perhaps investigate similar rides and compare them.

In addition, classes could choose to investigate / discuss Newton's three (3) laws and then attend ***Amusement Park Physics*** to apply them. This initial investigation could be done as a class or individually as a project.

This year's curriculum reflects the different demands that are placed on students in Science. We have sought to align the worksheets with the Provincial Ministry Science 10 guidelines.

Amusement Park Physics is designed to get students to get out of their classroom and explore real life science applications. Based on the current curriculum, students need to be able to design an investigation from start to finish, this includes data collection, analysis of results and communicating a conclusion.

Amusement Park Physics

We are excited to welcome you back to Playland for what is the 38th year of *Amusement Park Physics*. We are eager for teachers and students to get back into the park and apply their scientific knowledge to all the amazing rides, including our newest ride, ThunderVolt.

This project was started by James (Jim) Wiese in 1988 with his senior Physics students and was expanded in 1990 with the addition of the Grade 9 program. A while later Jim added an elementary school version called *The Science of Fun*. In 2008 a French Version for elementary schools was added called *La Science du Plaisir*, as well as a curriculum for Grade 8 and Grade 10 Science. In 2011 a version for Anatomy and Physiology 12 was added, and in 2012 a version for Chemistry 11 and Chemistry 12. Special thanks to Mike Eckert at Lord Tweedsmuir for helping with the Chemistry Module. 2016 saw the addition of activity sheets for the Beast and Haunted House. Rather than having them for specific grades, we added questions at the bronze, silver, and gold level. This allows teachers to choose the appropriate level for their students.

The purpose of *Amusement Park Physics* is to provide students with practice applying concepts learned in the classroom to real situations and experiences felt and seen on the rides. While working with a group of their peers or individually, students can problem solve, discuss possible solutions, communicate their ideas, and finally come to a conclusion about what they are experiencing. The process is far more important and rewarding than the final answer.

Due to the success of *Amusement Park Physics*, we have spread the event to five days in the spring and one day in the fall. You may choose any of these days but we will be limiting numbers to 2,500 students per day. These will be filled on a first come basis. This should help eliminate any lineups at the rides to ensure students make measurements multiple times on each ride.

There is a curriculum package for each grade level – Science 8, Science 10, Physics 11/12, Chemistry 11/12, and Anatomy and Physiology 12. You may choose to only download and print the version(s) that you will be using. Please feel free to adapt any materials to suit your needs.

I'd like to thank all those involved in *Amusement Park Physics 2026*: Michelle Pattison, Zach Wong, Jacob Simms, Rob Decman, Robert Browne, Jennifer Campbell, Peter Male and all the staff of the Pacific National Exhibition and Playland for their support. The work and dedication of all these people make *Amusement Park Physics 2026* possible.

2026 marks the third year that Jim Wiese will be taking a behind the scenes role and enjoying retirement a little more. I'm truly honored that Jim has entrusted me with the task of advancing *Amusement Park Physics*. I will ensure that for many years to come, students will continue to be welcomed at the park to apply the scientific principles they have learned in class. As a former Physics 11 attendee of *Amusement Park Physics* and now as a teacher, I understand the importance of having students get outside the classroom and explore science in a fun and engaging setting.

Look forward to seeing you at Playland,

Steve Simms

Materials in this package are under copyright with James Wiese and Science Plus. Permission is hereby given to duplicate this material for your use and for the use of your students, providing that credit to the author is given.

New Safety Regulations at Playland

Due to newly aligned amusement ride safety regulations in BC, hand-held measuring devices, or anything classified as a “loose item”, are not permitted on amusement park rides and attractions.

As portable G-Meters and accelerometers are no longer permitted, we recommend the use of a third-party accelerometer app on securely stored cell phones in place of these devices. Search for “accelerometer” and “roller coaster” to review the options available. Although we don’t endorse any specific apps, we have found the free app Phyphox to be effective. Please ensure accelerometer apps are downloaded to all devices in advance as Playland does not have Wi-Fi on site.

To securely store cell phones during ride cycles, students are permitted to bring their own arm bands or hip packs. Playland has a limited number of arm bands or hip packs that can be used by students who do not bring their own. Please ensure students who borrow Playland items return them at the end of each ride cycle.

As students are not permitted to hold devices while the ride is in operation, please ensure the app has been started prior to loading, as use of the app is not permitted while the ride is in motion.

Be sure to know and understand the orientation of the cell phone to properly interpret the data. We suggest you practice using it before coming to the park to understand how the data is interpreted with different orientations. Depending on your level of understanding and familiarity using the app(s), you may want to use the absolute value feature that will allow you to see just the magnitude.

The use of cell phone accelerometers is not required to experience Amusement Park Science. The exciting curriculum provides other questions or investigation opportunities that can be incorporated with many of our rides without the use of these accelerometers.

Note: Using your cellphone on a field trip is your responsibility. Playland is not responsible for any lost or damaged items.

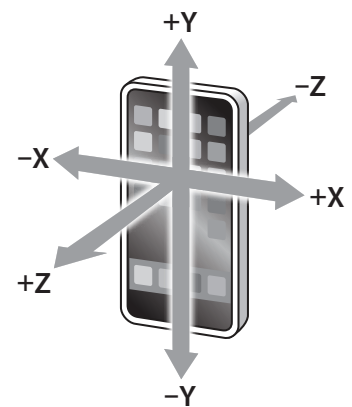

Table of Contents

page	i	Introduction
page	ii	Sample Timeline
page	iii	Site Map

SECTION A MAKING MEASUREMENTS

page	A-1	Time
page	A-1	Distance
page	A-3	Useful Formulae

SECTION B CONSTRUCTING THE EQUIPMENT

page	B-1	Astrolab
------	-----	----------

SECTION C SCIENCE 10 WORKSHEETS

page	C-1	Estimation at the Amusement Park
page	C-2	Atmosfear
page	C-4	Coaster
page	C-6	Coaster Graphing
page	C-9	ThunderVolt
page	C-10	Pirate Ship
page	C-12	Skybender
page	C-13	Rock-N-Cars
page	C-15	Scrambler
page	C-17	Enterprise
page	C-19	Hell's Gate
page	C-21	Gladiator
page	C-22	Dizzy Drop
page	C-23	Question Page
page	C-24	Science Day Quiz
page	C-25	First Nations Science

Introduction

The accompanying materials have been divided into several sections: one with information concerning measurements, one containing information on instrument construction, and one with the ride worksheets. Teachers are given flexibility for its use but are reminded that this educational program is used by many schools.

We try to have consistency between schools' implementation by asking each teacher to remind their students that this is an educational event. A rule of thumb is to have each student or group of students complete 3 or 4 of the modules. That is a reasonable expectation for them and keeps them on task during the day. Schools that are wishing to use this event as a reward for "hard work" through the year and that do not intend to have their students working on this material are asked to make arrangements to visit Playland at another time.

Students ***must*** be using the following materials throughout the day:

1. Packet of activities
2. Pencil
3. Timing devices (digital watches with stopwatch mode are nice)
4. Calculator

Critical Safety Note

As hand-held devices are not permitted on amusement park rides, students may use accelerometer apps installed in advance on cell phones. During rides, phones must be securely stored in arm bands or hip packs.

Sample Timetable

Please adapt to fit your circumstances

Time Schedule

8:30	Buses leave school
9:15	Arrive at Playland
9:30	Enter Playland Amphitheater for opening presentation
9:45 – 10:00	Opening Presentation at Playland Amphitheater
10:00	Gates to Playland open to admit students
10:00 – 2:00	Carry out pre-planned activities involving observations and measurements of selected aspects of the rides. Arrange a meeting time with your teacher for problems that arise or questions you have.
2:00	Playland closes and event ends
2:15	Board buses for return to school
3:00	Buses arrive back at school

Things to Bring:

- Lunch (You will NOT be allowed to leave the park for lunch)
- Pencil
- Calculator (app on most phones)
- This assignment package!
- A watch or device with seconds and a stopwatch mode to record times on the rides

SITE MAP

Playland Amusement Park

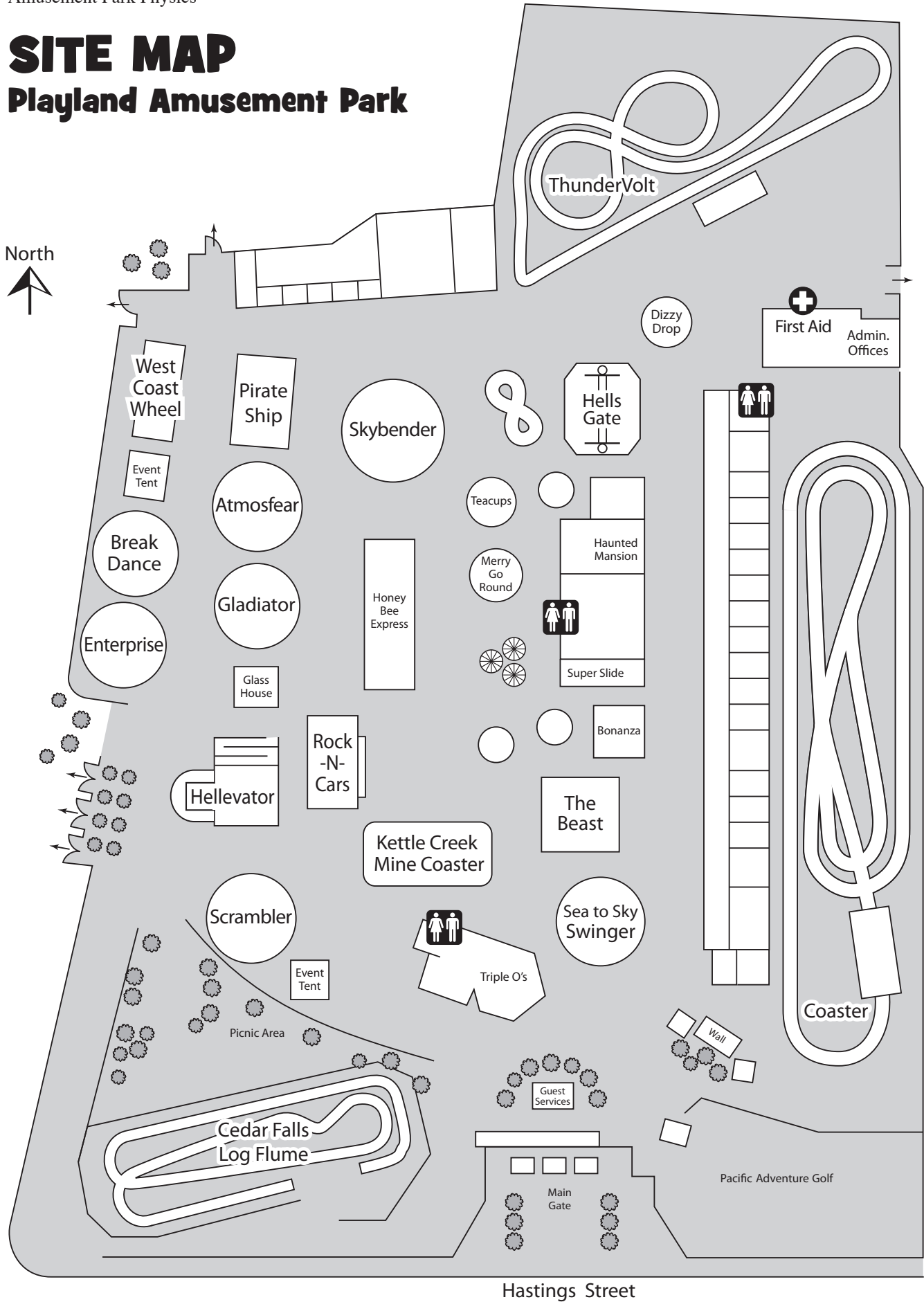

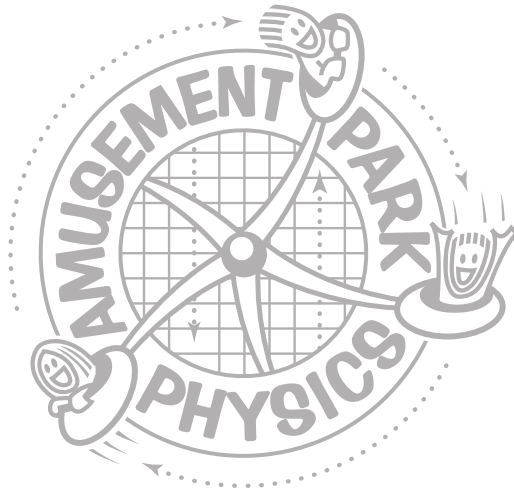

Section A

Making Measurements

page A-1 Time

page A-1 Distance

page A-3 Useful Formulae

Time

The times that are required to work out the problems can easily be measured by using a watch with a second hand or a digital watch with a stop watch mode. When measuring the period of a ride that involves harmonic or circular motion, measure the time for several repetitions of the motion. This will give a better estimate of the period of motion than just measuring one repetition. You may want to measure the time two or three times and then average them.

Distance

Since you cannot interfere with the normal operation of the rides, you will not be able to directly measure heights, diameters, etc. All but a few of the distances can be measured remotely using the following methods. They will give you a reasonable estimate. Try to keep consistent units, i.e. meters, centimeters, etc., to make calculations easier.

Pacing: Determine the length of your stride by walking at your normal rate over a measured distance. Divide the distance by the number of steps and you can get the average distance per step. Knowing this, you can pace off horizontal distances.

My pace = _____ m

Ride Structure: Distance estimates can be made by noting regularities in the structure of the ride. For example, tracks may have regularly spaced cross-members as shown in *figure a*. The distance d can be estimated, and by counting the number of cross members, distances along the track can be determined. This method can be used for both vertical and horizontal distances.

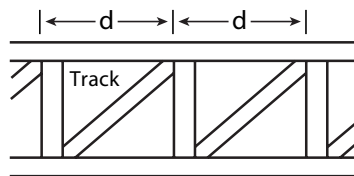

figure a

Triangulation: For measuring height by triangulation, an astrolab such as that shown in *figure b* can be constructed.

Practice this with the school flagpole before you come to Playland.

Suppose the height h_T of the **Roller Coaster** must be determined.

- 1 Measure the distance between you and the ride. You can pace off the distance.

distance d = _____ m

- 2 Measure the height of the string hole.

string hole height h_2 : h_2 = _____ m

3 Take a sighting at the highest point of the ride.

4 Read off the angle of elevation.

angle of elevation _____ °

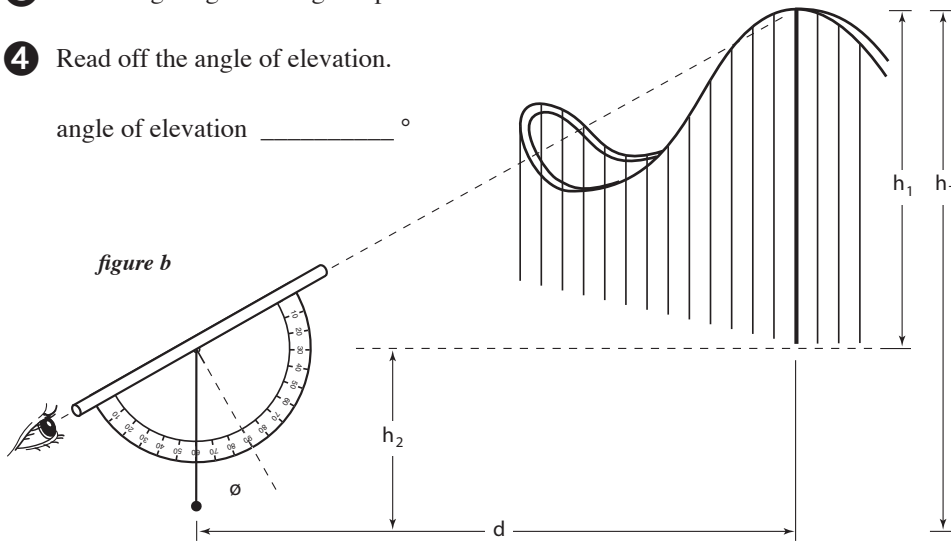

Then since $h_1/d = \tan \phi$
 $h_1 = d (\tan \phi)$

5 Look up the tangent value for the angle measured:

tangent value: _____

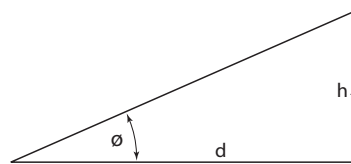

angle	tangent	angle	tangent	angle	tangent
0°	.00	30°	.58	60°	1.73
5°	.09	35°	.70	65°	2.14
10°	.18	40°	.84	70°	2.75
15°	.27	45°	1.00	75°	3.73
20°	.36	50°	1.19	80°	5.67
25°	.47	55°	1.43	85°	11.43

6 Multiply this tangent value by the distance from the ride: $h_1 = \underline{\hspace{2cm}} \text{ m}$

7 Add this product to the height of the string hole: $+ h_2 = \underline{\hspace{2cm}} \text{ m}$

This number is the height of the ride. $h_T = \underline{\hspace{2cm}} \text{ m}$

Useful Formulae

Circumference of a circle

$$C = 2\pi r \quad \pi = 3.14$$

$r = \text{radius of the circle}$

Example: What is the circumference of a circle with a radius of 10 m?

$$C = 2\pi r$$

$$= (2)(3.14)(10)$$

$$= 62.8 \text{ meters}$$

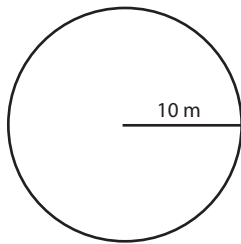

Speed of an object in a straight line

$$v = \frac{d}{t} \quad \text{speed} = \frac{\text{(distance travelled)}}{\text{(time for the trip)}}$$

Example: What is the speed of a roller coaster if it takes 53 seconds to make a trip of 700m?

$$v = \frac{d}{t}$$

$$= \frac{700 \text{ m}}{53 \text{ sec}}$$

$$= 13.2 \frac{\text{m}}{\text{sec}}$$

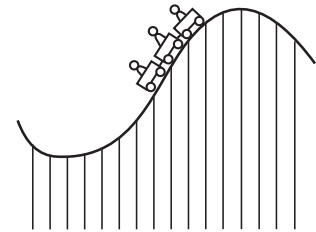

$$V_{\text{ave}} = \frac{\Delta x}{\Delta t} \quad \text{average velocity} = \frac{\text{(change in position)}}{\text{(change in time)}}$$

Speed of an object in a circle

$$v = \frac{2\pi r}{t} \quad \text{speed} = \frac{\text{(distance travelled)}}{\text{(time for the trip)}}$$

(t = time for one revolution)

Example: What is the speed of a car around a ride that has a 10m radius and takes 6.1 seconds to make one revolution?

$$v = \frac{2\pi r}{t}$$

$$= \frac{2(3.14)(10 \text{ m})}{6.1 \text{ s}}$$

$$= 10.3 \frac{\text{m}}{\text{sec}}$$

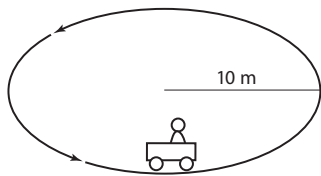

t = 6.1s

Acceleration of an object in a straight line

$$a = \frac{\Delta v}{\Delta t} \quad \text{acceleration} = \frac{\text{(change in velocity)}}{\text{(change in time)}}$$

$$\Delta v = v_f - v_i$$

change in velocity = final velocity – initial velocity

Example: What is the acceleration of the roller coaster down the hill if it increases in speed from 5 m/s at the top to 11 m/s at the bottom in 2.5 seconds?

$$a = \frac{\Delta v}{\Delta t}$$

$$= \frac{(v_f - v_i)}{\Delta t}$$

$$= \frac{(11 \text{ m/s} - 5 \text{ m/s})}{2.5 \text{ s}}$$

$$= \frac{6 \text{ m/s}}{2.5 \text{ s}}$$

$$= 2.4 \text{ m/s}^2$$

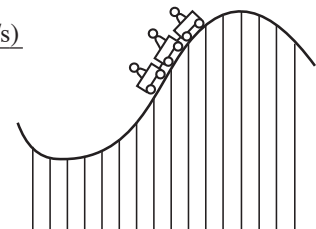

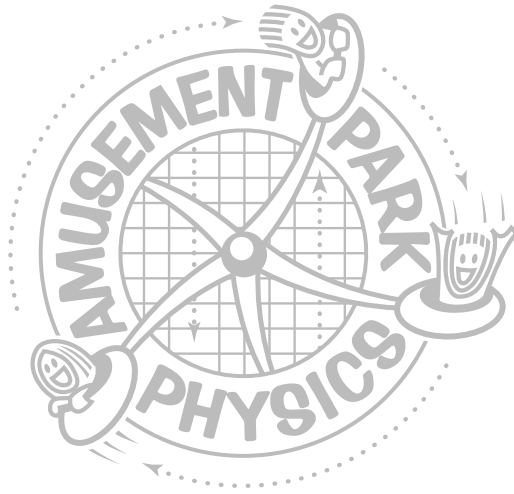

Section B

Constructing The Equipment

ASTROLAB

Triangulation Instrument and Accelerometer

1. Cut out the Astrolab.
2. Fold the top section over a pencil and roll it down to the heavy double line to make a sighting tube.
3. Tape the rolled paper tube closed and then let the pencil slide out.
4. Glue the Astrolab to a 8" x 5" index card and trim.
5. Take about 20 cm of heavy thread and tie one end to a weight such as a key or washer. Tie the other end through the hole at the top of the Astrolab.
6. Let the thread hang free. The angle it marks is the angular height of an object seen through the tube.

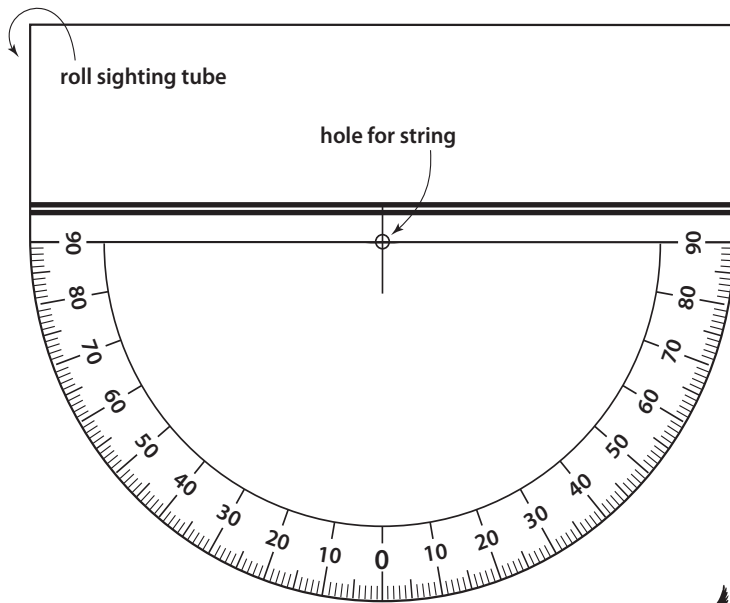

For instance:

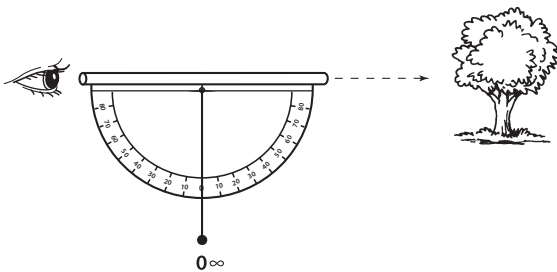

An object on the horizon has an angular height of 0 degrees.

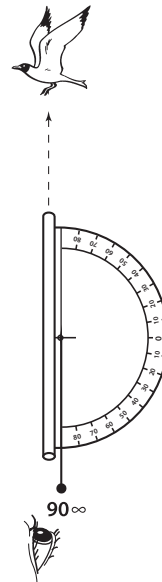

An object directly overhead has an angular height of 90 degrees.

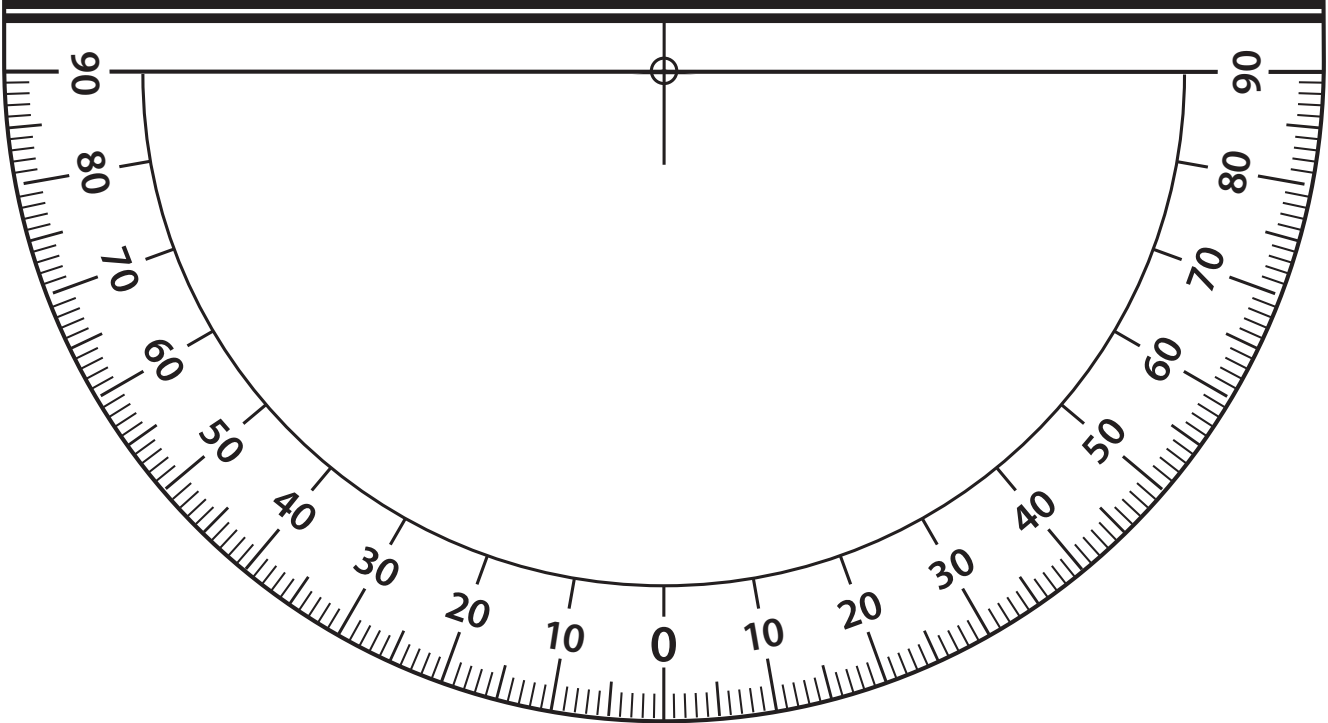

Amusement Park Physics

Section B • Constructing the Equipment

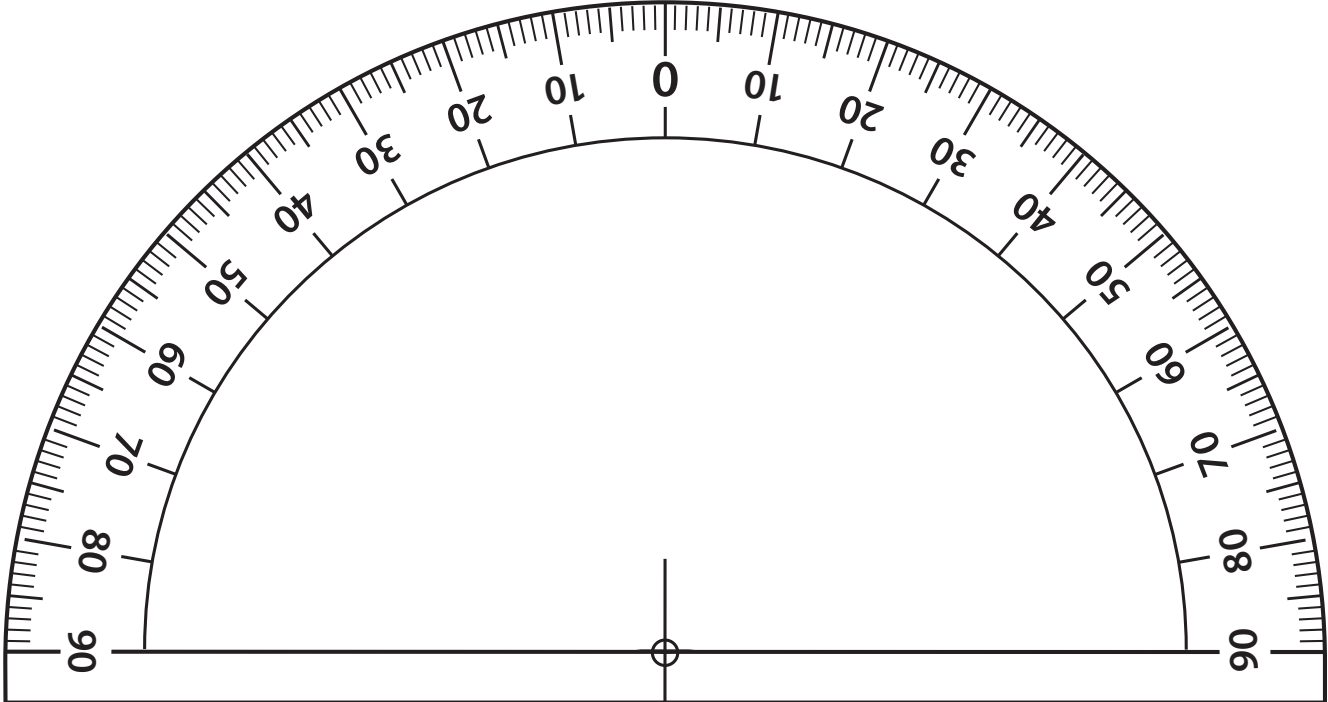

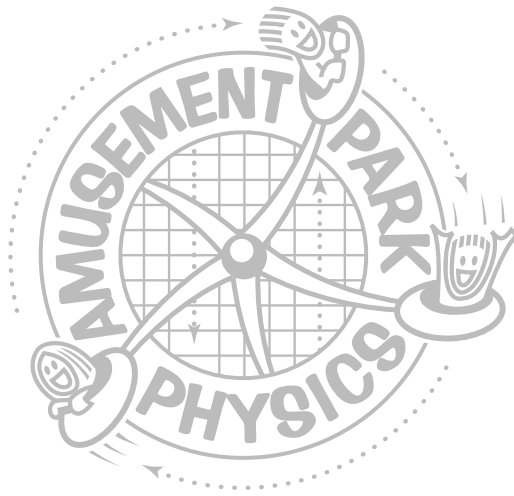

Section C

Science 10 Worksheets

page C-1	Estimation at the Amusement Park
page C-2	Atmosfear
page C-4	Coaster
page C-6	Coaster Graphing
page C-9	ThunderVolt
page C-10	Pirate Ship
page C-12	Skybender
page C-13	Rock-N-Cars
page C-15	Scrambler
page C-17	Enterprise
page C-19	Hell's Gate
page C-21	Gladiator
page C-22	Dizzy Drop
page C-23	Question Page
page C-24	Science Day Quiz
page C-25	First Nations Science

Estimation at the Amusement Park

One skill that is important in science is *estimation*. An estimation gives you an approximate answer before you solve a problem. This estimation will tell you if your answer is reasonable. Try the following activities and sharpen your estimation skills. For each question, give your estimation *and the reasoning you used* to obtain that estimation. Remember, an estimation is not just a guess.

Questions

① How tall is the Hellevator tower?

② What is the average speed of the Coaster for a complete trip?

③ How many times does the Enterprise rotate during one day of operation?

④ How many soft drinks do all the concession stands combined sell during one day at Playland?

⑤ How many people are at Playland today?

Atmosfear

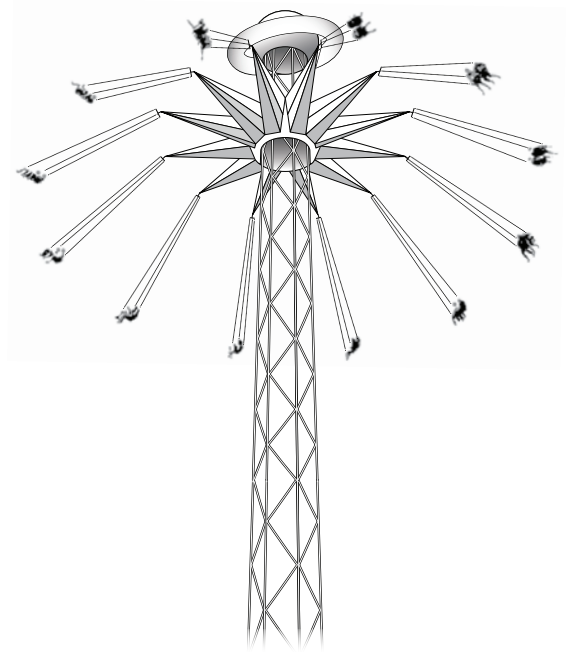

A. Data

- 1 Distance from center of rotation to seat when ride is going full speed _____ m
- 2 Time for three revolutions _____ s
- 3 Time for one revolution _____ s

B. Qualitative Tasks

- 1 Watch the ride from the beginning until it reaches full speed. What happens to the seats as the ride increases in speed? Why?

- 2 What force causes the seats to change position?

- 3 Describe your sensations as the ride increased in speed. Do you feel different looking at the chair in front of you compared to watching objects as they move by?

- 4 Will an empty swing or one with someone in it ride higher? Why?

- 5 During the ride, when do you feel the heaviest? the lightest?

- 6 Do you experience a greater centripetal force when you're going faster or slower? Why do you think this is?

- 7 How is this ride similar to and different than the Sea to Sky Swinger? Are the physics different?

- 8 What effect does the height of the ride have on the centripetal force created in the ride? What affect does its height have on the thrill of the ride?

calculations

C. Quantitative Calculations

❶ Guess how fast you go on this ride.

_____ km/hr

❷ Calculate the distance you travel in one revolution of the ride at full speed.
(Hint: It's the circumference of a circle).

_____ m

❸ Calculate the speed you travel at during the ride.
(Hint: Use velocity formula). Convert to km/hr.

_____ m/s

_____ km/hr

❹ Compare #1 and #3. Explain the difference.

Coaster

A. Data

Length of track 1,001 m

- 1 How many slopes are involved in this ride? _____
- 2 Estimate the height of the first hill. _____ m
- 3 Estimate time (in seconds) for the following questions:
 - (a) Time for one trip? _____ s
 - (b) Time it takes for train to go from bottom to top of first hill? _____ s
 - (c) Time it takes for train to go from top to bottom of first hill? _____ s

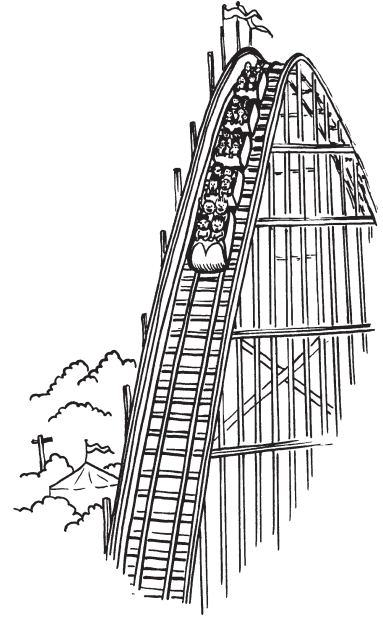

B. Qualitative Observations

- 1 Where was the highest hill on the ride? Why was it there?

- 2 Were you thrown from side to side in the train? If so, what forces caused that feeling?
 (Use a diagram if necessary to help explain).

- 3 Where on the ride did you feel you were going the fastest? Why?

- 4 Where on the ride did you feel like you were lifted off your seat?
 How did the ride cause that feeling?

- 5 Why are there no seatbelts which strap you into this ride?

- 6 What would happen if you raised your arms up in the air at the crest (top) of a hill
 and left them up as you descended?

calculations

C. Quantitative Calculations

- 1 Calculate the average velocity for the Coaster of one ride.

_____ m/s

_____ km/hr

- 2 Explain, in terms of forces, the difference between the time it takes:

(a) to get up a hill

(b) to get down a hill

- 3 List the types of friction which affect the train throughout the entire ride.

- 4 Show in a simple diagram of the ride, one place where your car is:

(a) accelerating

(b) decelerating

- 5 What is the distance the coaster travels in one ride? What is the displacement? Explain.

- 6 How would the coaster work on the Moon? Explain your answer.
(Think about the acceleration due to gravity on Earth and the Moon.)

Coaster Graphing

One way to calculate the height of a ride is by using a type of mathematics called *trigonometry*. Trigonometry is the study of the relationship among the sides and angles of triangles. These relationships are called trigonometric ratios. In this case, you'll use the tangent ratio.

Procedure

- 1 Measure or estimate a distance that is **31 m** from the base of the Coaster hill you are measuring.
- 2 Face the hill, then look at the top of it sighting through the tube on the astrolabe. Instructions for making your astrolabe are in Section B.
- 3 Without moving the position of the astrolabe, read the degrees where the string touches the astrolabe.
- 4 Use the chart below to approximate the height of the object. Interpolate between these data values for angle measurements that aren't multiples for five.
- 5 Remember that there are other ways to measure heights and distances. Refer to Section A for more ideas. You can also use other distances from the hill and their trigonometric values if you prefer.

$$\tan \theta = \frac{\text{opposite side length}}{\text{adjacent side length}}$$

- 6 Record the time to reach each point in the data table below. Start with **t = 0** at the beginning of the ride.

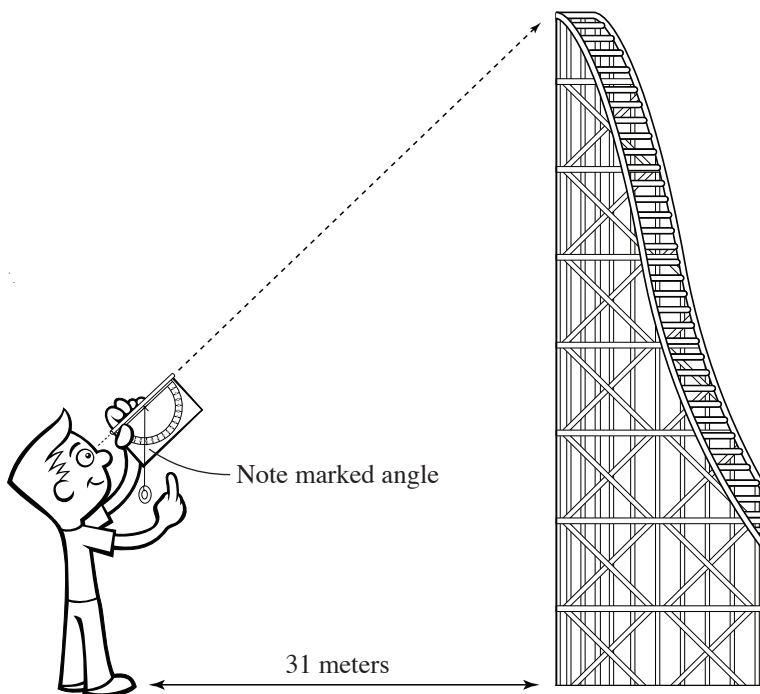

Angle (in degrees)	Height of the Object (in metres)
5	2.7
10	5.4
15	8.2
20	11.2
25	14.4
30	17.8
35	21.5
40	25.8
45	31.0
50	36.7
55	43.9
60	53.3

Data

Find the height of the Coaster locations using trigonometry.

The blank spaces will let you put in other locations of your choice..

Location on the Coaster	Estimated Height from the ground (in m)	Time to reach this point (in s)
Start of the ride		
Bottom of first hill		
Top of first hill		
Bottom of second hill		
Top of second hill		
Bottom of next hill		
End of Ride		

Questions

- 1 Draw a graph of height (vertical axis) vs. time (horizontal axis), using the data from your Data Chart, on the graph at the right.

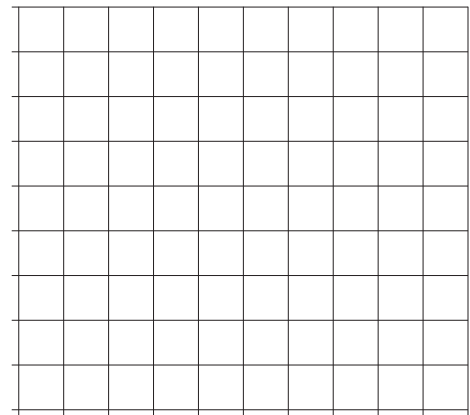

- 2 Describe the shape of your graph. Does it have a regular or irregular shape?

- 3 What does it mean when your graph shows a horizontal line?

4 What does it mean when your graph shows a line that it moving upward?
What happens the motion of the cars then?

5 What does it mean when your graph shows a line that is moving downward?
What happens to the motion of the cars then?

6 What does the slope of the line on your graph tell you about the motion of the ride?

7 How would your graph be different if you selected a height of 0 for the starting point of the ride?

Bonus Question

Collect data and draw a graph of the velocity vs. time for a ride on the Coaster.

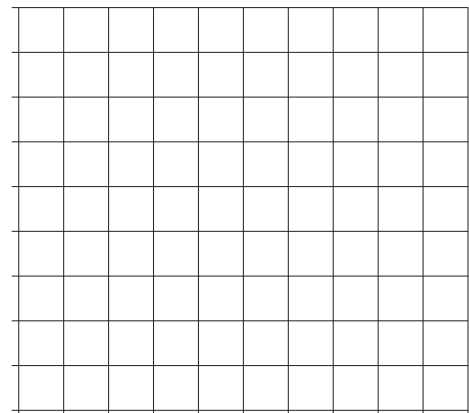

ThunderVolt

The ThunderVolt, Canada’s newest and fastest electric launch coaster, blasts off through an illuminated tunnel and up a steep incline before a thrilling drop.

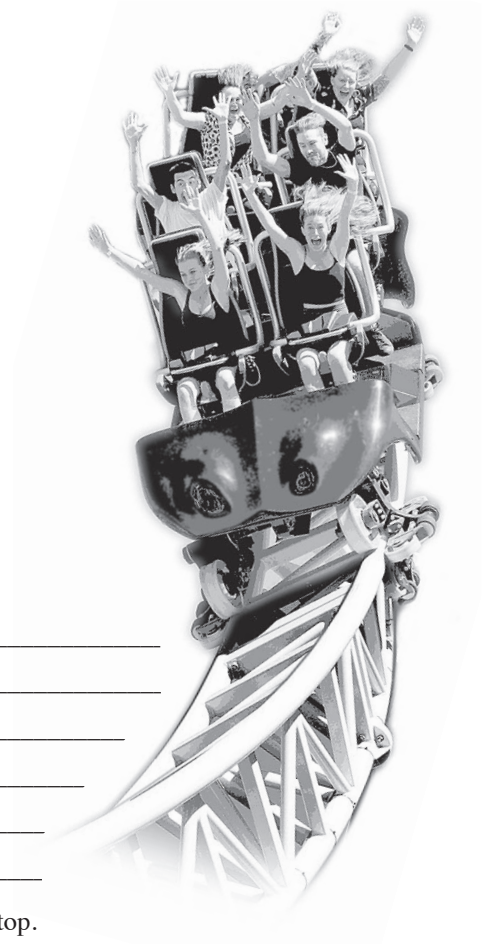

A. Data

Mass of the car(s) 6,110 kg
Estimate the height of the first hill _____ m
Estimate the time it takes for the cars to accelerate _____ sec

B. Questions

1 When observing the ThunderVolt for the first time, how is it different from the wooden roller coaster? How do you think it will feel different?

2 Using your estimation of the height, calculate the required energy to get to the top.

3 Using the estimated time it takes to accelerate the cars, calculate the required power.

4 Suppose that the required power is 510 kilowatts. What is the lost energy in joules?

5 The magnets in the motor are cooled by coolant with a total mass of 35 kg. Determine the required specific heat capacity of the coolant if there is only a two (2) degree change in temperature.

Pirate Ship

A. Data

- 1 **Challenge:** Estimate the vertical distance from the top to the bottom of the ride. _____ m
- 2 How long does it take for this ride to make on complete swing? _____ s
- 3 The motion of this ride is a good example of a _____
- 4 Give examples of other devices that use this motion:

- 5 How long does the whole ride last? _____ s
- 6 How many full swings does the pirate ship make?
 (a complete cycle is the time to swing over and back). _____

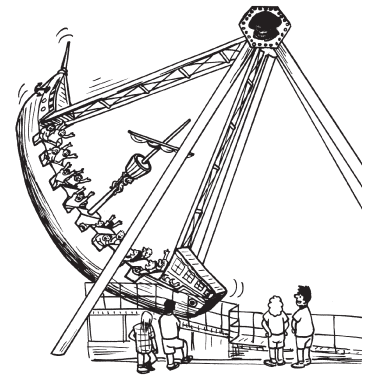

B. Qualitative Tasks

- 1 When does the ride seem to be accelerating?

- 2 When does the ride seem to decelerating?

- 3 a) What forces are acting upon you during this ride?

- b) Why do you think seatbelts are not used for this ride?

4 Draw *simple* diagrams indicating at what point the forces acting upon the ride are:

a) balanced

b) unbalanced

5 What term can you use to describe the force acting upon you at the point when the bow or stern of the pirate ship is highest?

Skybender

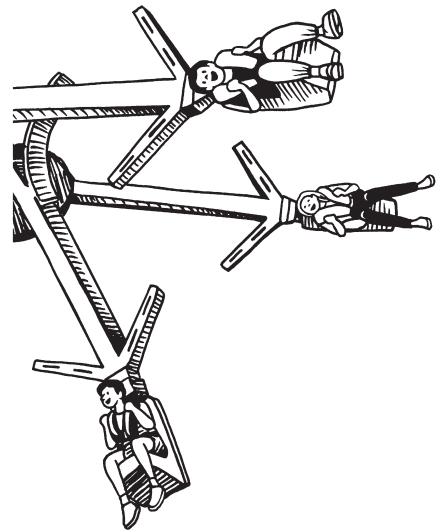

Data

Estimated distance from centre of rotation to seat
(when in the rest position) _____ m

Estimated distance from centre of rotation to seat
(in extended position) _____ m

Time for one revolution of the ride at max speed _____ sec

Questions

1 Describe the sensations that you felt on the ride, including what happened as the ride increased in speed.

2 Where do you feel the heaviest and where do you feel the lightest?

3 Explain your answers to questions 1 and 2 using your knowledge of forces.

4 Calculate the average speed of the rider as they move in a circle at maximum speed. (Circumference / time for 1 rotation)

5 Do you think you're going faster at the top of the extension or bottom? Explain.

Rock-N-Cars

A. Qualitative Tasks

Make observations that will allow you to answer the following questions.
State the observed facts that justify each of your answers.

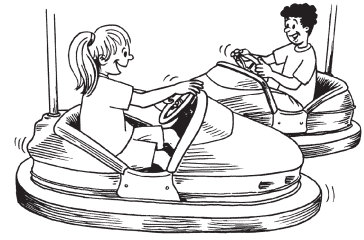

1 List all energy transformations which take place from beginning to end of this ride.

2 In words or short phrases, describe what it was like to participate in this ride.

3 Do you have much control over movement by using the steering wheel? Why or why not?

4 Can you go in reverse? If so, discuss how this is done.

5 Draw, using arrows, the direction of the forces which act upon your spine and neck when you are hit by another car.

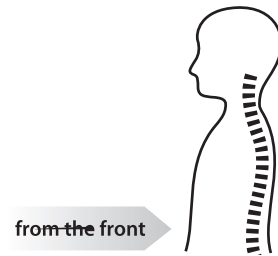
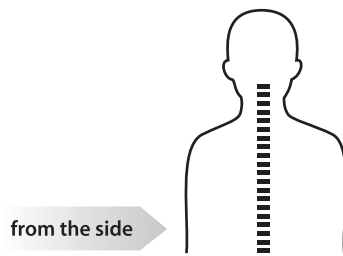
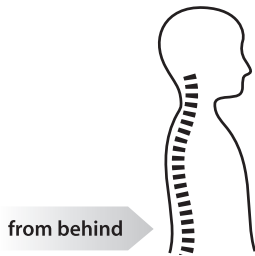

6 Draw three step by step simplified diagrams which show (“slow motion”) how your body might react to a collision.

step 1

step2

step3

7 Predict what would happen if:

a) there were more bumper cars;

b) there were fewer bumper cars;

c) the bumper cars were bigger;

d) the bumper cars were smaller;

e) the bumpers on the cars were larger;

f) the bumpers on the cars were smaller.

8 Discuss the function of the safety strap by answering the following questions:

a) Does the strap adequately hold you in place upon impact from the side?
from the front? from the rear?

b) Is it long enough to fit you comfortably?

c) How would the strap help you if, somehow, you flipped the bumper car?

9 Suggest an alternative design to the bumper car safety strap.

10 Complete the following chart with a word or short phrase:

How I felt before the ride

How I felt after the ride

Scrambler

A. Data

- 1 Length of time for complete ride. _____ s
- 2 Length of time for seat to make a small circle/the seat will go back and forth across the ride twice during each small circle. _____ s
- 3 Was the rotation clockwise or counterclockwise around primary axis? _____
- 4 Was the rotation clockwise or counterclockwise around secondary axis? _____

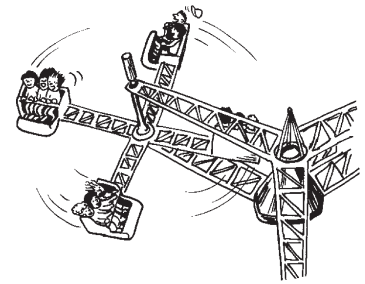

- 5 Concentrate your attention on one rider, and follow this single rider's path for at least one full rotation of the ride. Draw the path of the rider for one full rotation. *(Your diagram should be what you would see if you watched the rider's path while looking down on the ride from above.)*

B. Qualitative Tasks

- 1 Describe the sensations you felt during the ride.

- 2 Are the forces you feel the same for the whole ride? Explain any difference.

3 What would happen if both the primary and secondary rotation were in the same direction? How would a ride like that feel? On your diagram, show where forces are the most and where they are the least.

4 Where do you feel you travel the fastest? Where the slowest?

calculations

C. Quantitative Calculations

1 Approximate total distance travelled for the ride.

_____ m

2 Average speed

_____ m/s

_____ km/hr

3 Draw a diagram showing both rotation axes. Where is acceleration additive (in same direction)? Where is acceleration in opposite direction?

4 Draw the net acceleration at each point in #3 (using vector arrows).

Enterprise

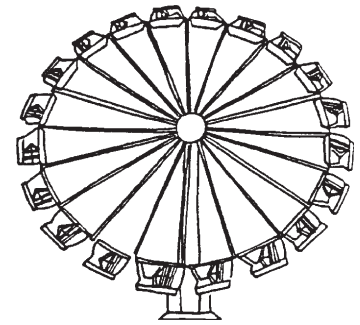

A. Data

- 1 Radius of the ride _____ m
- 2 Time of one revolution when ride is at full speed. _____ s

B. Qualitative Tasks

- 1 Observe the Enterprise as it is starting out. As it starts to move in a horizontal orbit, what do you notice about the cars in relationship to the ride?

- 2 Continue to watch the ride as it changes from horizontal to vertical. Now what do you notice about the cars in relationship to the ride?

- 3 Why do you suppose that the cars changed their positions?

- 4 In the upside down part of the ride, do you feel like you are going to fall down? If not, explain why.

- 5 Towards the middle where the ride spins, does the center appear to be going faster or slower than the cars? Measure it out. What did you find?

- 6 While riding the ride, notice at what particular point you appear to be going faster. Where on the ride do you feel this? (At the top, bottom, etc.) Why do you suppose that this is so?

- 7** Also notice at what point in the ride you appear “heavier”.
Where on the ride do you feel this? Why do you suppose that this is so?

- 6** How do you feel as you leave the ride?

calculations

C. Quantitative Calculations

- 1** Calculate the circumference of the ride.

_____ m

- 2** Calculate the frequency of the ride at full speed.

_____ rev/s

- 3** Calculate your speed in the ride at full speed.

_____ m/s

_____ km/s

Hell's Gate

Stand in a position where you can observe the ride. Take data and answer the following questions. After reading the questions, you must determine what data you need to collect.

A. Data

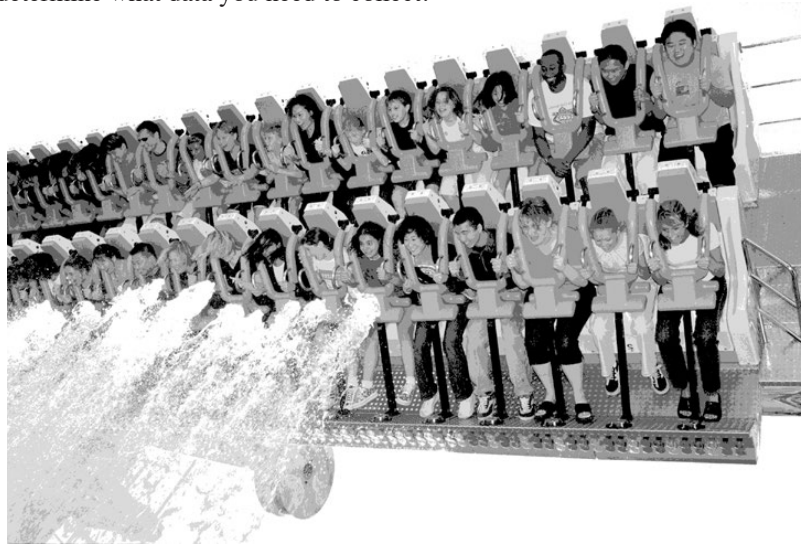

Measurements while on ride: (using cell phone accelerometer app)

Maximum **g** _____ g's at _____ (location)

Minimum **g** _____ g's at _____ (location)

B. Qualitative Tasks

1 Have the riders take their pulse rate:

- a) before they get on this ride. _____
- b) immediately after they have finished this ride. _____

2 In a few words, have the riders describe how they felt:

- a) before the ride started _____
- b) during the ride _____
- c) after the ride ended _____

3 Where on the ride do the riders experience:

- a) more g's than normal _____
- b) less g's than normal _____

- 4 Explain the riders' sensations and the g's they felt in #3 in terms of the physics of the ride.

calculations

C. Quantitative Tasks

- 1 Calculate the average speed during the ride in m/s.

_____ m/s

- 2 Estimate the mass of the ride and the riders.

_____ kg

- 3 Calculate the amount of work necessary to move the ride and the riders from the lowest point to the highest point on the ride.

_____ Joules

- 4 How much power do the motors have to supply to move the ride and the riders in calculation #3?

_____ kW

- 5 Present data and calculations for any other portion of the ride.

Gladiator

This ride uses unusual centripetal force.

Procedure and Questions

Ride the Gladiator and answer the following questions.



- 1 Does the large wheel at the centre of this ride turn clockwise (move to the left) or counter-clockwise (move to the right)? What other motion does the ride have?

- 2 Describe the forces you felt while on the ride. Are the forces always the same or do they change during the ride? If the forces change on the ride, where do they change?

- 3 How many g's does this ride create? Are the g's constant or do they change? Explain your answer.

- 4 Concentrate your attention on one rider during the ride and follow this single rider's path for at least one full revolution of the ride. Draw a diagram of the path he took for that single revolution. (*Your diagram should be what you would see if you watched the rider's path while looking down on the ride from above.*)

Dizzy Drop

The Dizzy Drop is like the Hellevator but scaled down. Don't let its smaller size fool you. Even though it's not as tall, it can still cause you to grip the safety bar a little tighter.

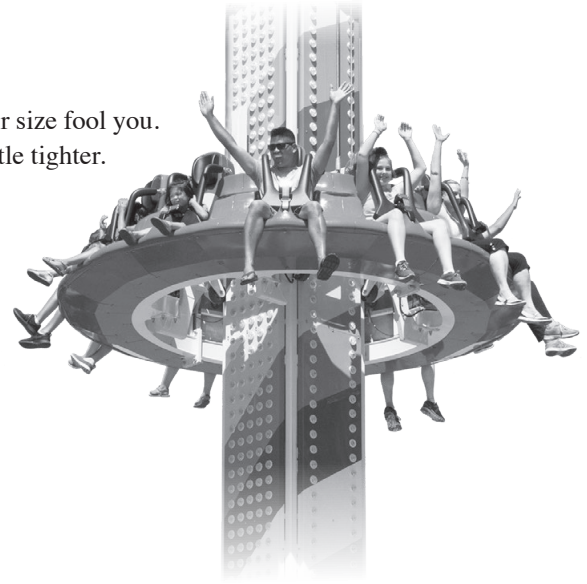

Data

Ride time	90 seconds
Direction of travel	up and down
Vertical speed	max deceleration 2.5 g

Questions

1 Using the astrolab, calculate the height of Dizzy Drop.

2 Using your answer from question #1, calculate the maximum potential energy at the top of Dizzy Drop.

3 Pretend that at the very top, the ride drops you in a free fall. Using your answer from question #2, determine your final velocity right before hitting the ground.

Question Page

Instructions

Choose one ride only and make up 10 of your own science questions specifically on that ride.

1. _____

2. _____

3. _____

4. _____

5. _____

6. _____

7. _____

8. _____

9. _____

10. _____

List five (5) surprising (unexpected) things that you discovered during **Science Day**.

1. _____

2. _____

3. _____

4. _____

5. _____

Science Day Quiz

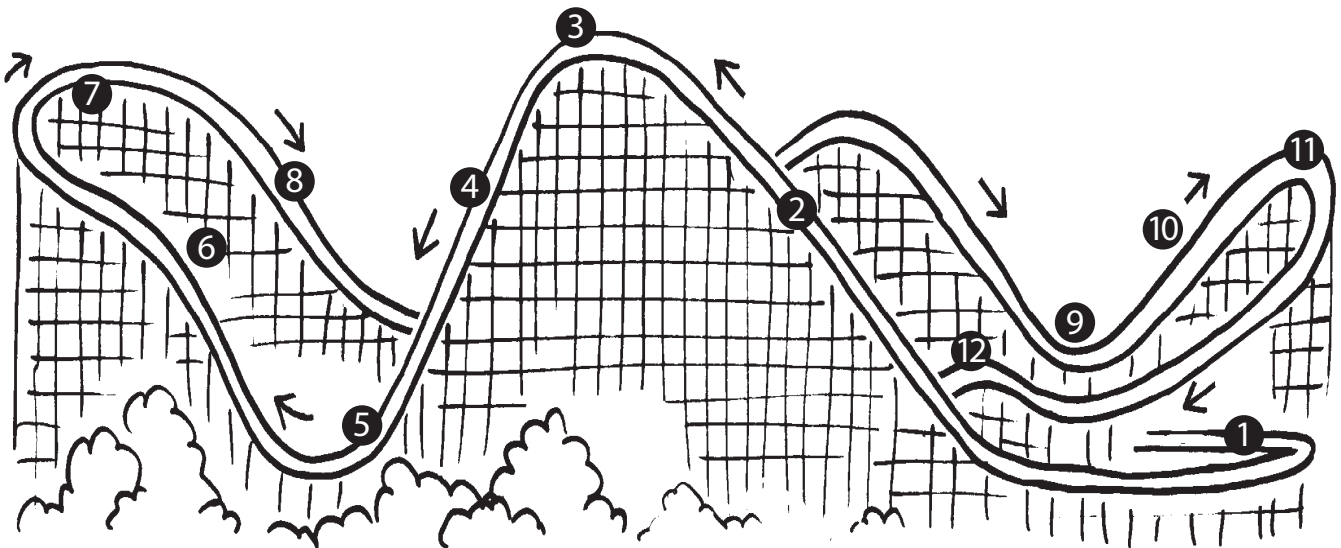

List the number (or numbers) on the roller coaster that best match the phrases below:

- _____ freefall area
- _____ weightless zone
- _____ where a machine makes the ride go instead of gravity
- _____ where car moves because of momentum roll
- _____ banked curve
- _____ parabolic arc
- _____ centripetal force at work
- _____ greatest gravitational potential energy
- _____ where the coaster's velocity increases
- _____ high g-force zone
- _____ where car moves the slowest assuming a frictionless track
- _____ where riders decelerate
- _____ greatest kinetic energy

First Nations Science

We are taught and learn a Euro-centric view of science. That makes sense because in North America we were settled mainly by Europeans. But there are other points of view that are often overlooked. In this activity you will be given a chance to explore other points of view and contributions to science by other cultures. To make it easier we will divide it into sections: *transportation, housing, food and agriculture*, and others like *astronomy, medicine, fishing, sustainability, and environment*. So, here we go...



Transportation

There are many surfaces we have to travel over: rivers, oceans, lakes, land, mountains, etc. Start with water. Two ways to travel on water are rowboat and canoe. Compare them. Research their use and development. Which is better for Canadian rivers, lakes, rapids, northern waters and oceans? Be prepared to present your findings to your class.



Next look at land travel. What are ways to move over land, including both flat land and mountains? Again be prepared to present your findings to your class.

Food and Agriculture

The origin of the foods we eat come from many places. Select a food and research it. Focus on its origin and importance to our diet. Which foods have a First Nations origin and which came from other countries?

Astronomy

When humans developed into a farming society, it became important to know the yearly cycle and the seasons. There are examples of this around the world, from Stonehenge in England to structures in Mexico like Tulum and Chichen Itza. There are also several First Nations examples. For this topic, research one example of how we measure a year. Look at both past examples and modern ones.

Another thing people have done is look at the stars. They notice shapes of images that some stars seem to make, called constellations. Research one constellation. Draw a picture of the image made by the stars and write about the legend or story that goes with it. Do the First Nations people have a different name and story? Is the name or story different in another country? Finally, draw your own constellation of 3 to 5 stars. Draw the image they make and write a story about the image. Be prepared to tell the class what you learned.

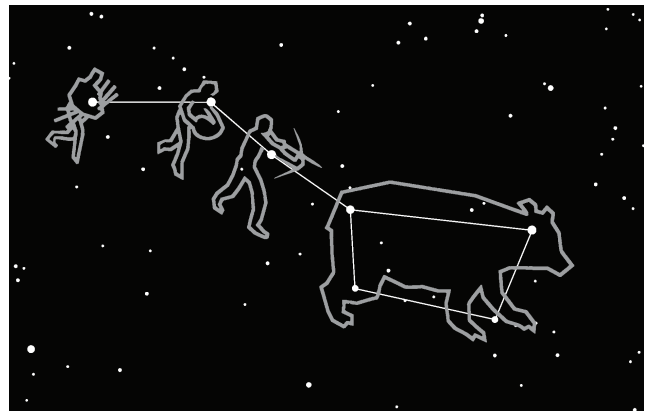

Medicine

Medicines and health remedies come from many places. For this topic, research the history of one medicine. Be prepared to present your findings to the class. Which medicines have a First Nations origin?

Fishing

Besides plants, fish have long been a part of the human diet. Research one kind of food fish. Where does it live and how is it caught? Are these methods sustainable? Finally, has the fish been important for First Nations?

Summary

Write three things you have learned in this activity that you didn't know before. What is one question you still have about First Nations science? How could you answer your question? Be prepared to share this with the class.

