

Amusement Park

PHYSICS



PLAYLAND

**PHYSICS and
SCIENCE DAY
2026**

.....
Science 8

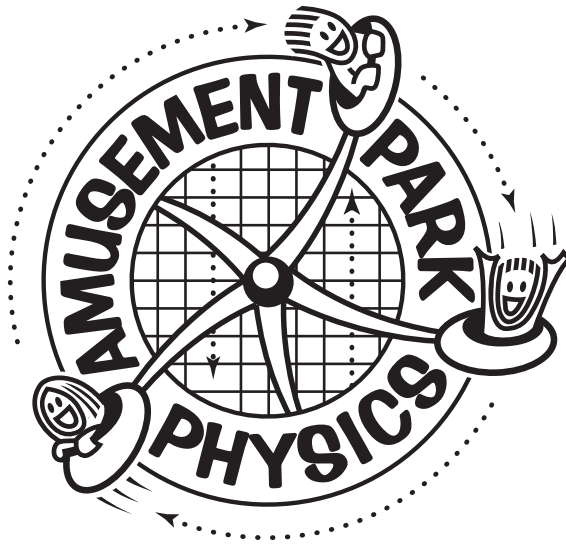

These educational materials were created by *Science Plus*.
For more information on Amusement Park Science
contact Steve Simms
simms_s@surreyschools.ca

Illustrations and graphic design by *Robert Browne Graphics*
Email: rbgraphics@telus.net • Tel: 604-460-2804

Vancouver, B.C., Canada
April 2026

Materials in this package are under copyright with James Wiese and Science Plus.
Permission is hereby given to duplicate this material for your use and for the use of
your students, providing that credit to the author is given.

Amusement Park Physics

and the new Secondary School Curriculum

Over the past few years, the educational system has seen a shift in the science curriculum and changes to how that curriculum is delivered. The current curriculum is more inquiry based with a focus on questioning, predicting, communication, planning and conducting investigations. In addition, students are asked to analyse not only the data they collect, but also the process that was used to collect the data.

The curriculum for Science has changed. Although some of the topics may not be in the curriculum for a certain course, inquiry and investigation are at the forefront. *Amusement Park Physics* can now be applied to any number of classes as they all include an inquiry / investigative component. Teachers are able to adapt or enhance the curriculum packages currently supplied by *Amusement Park Physics* as they see fit. This gives you, as an educator, tremendous flexibility in terms of how you and your class spend your time at Playland. You could focus on one ride and do an in-depth study or perhaps investigate similar rides and compare them.

In addition, classes could choose to investigate / discuss Newton's three (3) laws and then attend *Amusement Park Physics* to apply them. This initial investigation could be done as a class or individually as a project.

This year's curriculum reflects the different demands that are placed on students in Science. We have sought to align the worksheets with the Provincial Ministry Science 8 guidelines.

Science 8: "Demonstrate a sustained intellectual curiosity about a scientific topic or problem of personal interest"

"Collaboratively plan a range of investigation types, including field work and experiments, to answer their questions or solve problems they have identified"

"Observe, measure and record data (qualitative and quantitative), using equipment, including digital technologies, with accuracy and precision"

Science 9: "Collaboratively and individually plan, select, and use appropriate investigation methods, including field work and lab experiments, to collect reliable data (qualitative and quantitative)"

"Select and use appropriate equipment, including digital technologies, to systematically and accurately collect and record data"

Amusement Park Physics is designed to get students to get out of their classroom and explore real life science applications. Based on the current curriculum, students need to be able to design an investigation from start to finish, this includes data collection, analysis of results and communicating a conclusion.

Amusement Park Physics

We are excited to welcome you back to Playland for what is the 38th year of *Amusement Park Physics*. We are eager for teachers and students to get back into the park and apply their scientific knowledge to all the amazing rides, including our newest ride, ThunderVolt.

This project was started by James (Jim) Wiese in 1988 with his senior Physics students and was expanded in 1990 with the addition of the Grade 9 program. A while later Jim added an elementary school version called *The Science of Fun*. In 2008 a French Version for elementary schools was added called *La Science du Plaisir*, as well as a curriculum for Grade 8 and Grade 10 Science. In 2011 a version for Anatomy and Physiology 12 was added, and in 2012 a version for Chemistry 11 and Chemistry 12. Special thanks to Mike Eckert at Lord Tweedsmuir for helping with the Chemistry Module. 2016 saw the addition of activity sheets for the Beast and Haunted House. Rather than having them for specific grades, we added questions at the bronze, silver, and gold level. This allows teachers to choose the appropriate level for their students.

The purpose of *Amusement Park Physics* is to provide students with practice applying concepts learned in the classroom to real situations and experiences felt and seen on the rides. While working with a group of their peers or individually, students can problem solve, discuss possible solutions, communicate their ideas, and finally come to a conclusion about what they are experiencing. The process is far more important and rewarding than the final answer.

Due to the success of *Amusement Park Physics*, we have spread the event to five days in the spring and one day in the fall. You may choose any of these days but we will be limiting numbers to 2,500 students per day. These will be filled on a first come basis. This should help eliminate any lineups at the rides to ensure students make measurements multiple times on each ride.

There is a curriculum package for each grade level – Science 8, Science 10, Physics 11/12, Chemistry 11/12, and Anatomy and Physiology 12. You may choose to only download and print the version(s) that you will be using. Please feel free to adapt any materials to suit your needs.

I'd like to thank all those involved in *Amusement Park Physics 2026*: Michelle Pattison, Zach Wong, Jacob Simms, Rob Decman, Robert Browne, Jennifer Campbell, Peter Male and all the staff of the Pacific National Exhibition and Playland for their support. The work and dedication of all these people make *Amusement Park Physics 2026* possible.

2026 marks the third year that Jim Wiese will be taking a behind the scenes role and enjoying retirement a little more. I'm truly honored that Jim has entrusted me with the task of advancing *Amusement Park Physics*. I will ensure that for many years to come, students will continue to be welcomed at the park to apply the scientific principles they have learned in class. As a former Physics 11 attendee of *Amusement Park Physics* and now as a teacher, I understand the importance of having students get outside the classroom and explore science in a fun and engaging setting.

Look forward to seeing you at Playland,

Steve Simms

Materials in this package are under copyright with James Wiese and Science Plus. Permission is hereby given to duplicate this material for your use and for the use of your students, providing that credit to the author is given.

New Safety Regulations at Playland

Due to newly aligned amusement ride safety regulations in BC, hand-held measuring devices, or anything classified as a “loose item”, are not permitted on amusement park rides and attractions.

As portable G-Meters and accelerometers are no longer permitted, we recommend the use of a third-party accelerometer app on securely stores cell phones in place of these devices. Search for “accelerometer” and “roller coaster” to review the options available. Although we don’t endorse any specific apps, we have found the free app Phyphox to be effective. Please ensure accelerometer apps are downloaded to all devices in advance as Playland does not have Wi-Fi on site.

To securely store cell phones during ride cycles, students are permitted to bring their own arm bands or hip packs. Playland has a limited number of arm bands or hip packs that can be used by students who do not bring their own. Please ensure students who borrow Playland items return them at the end of each ride cycle.

As students are not permitted to hold devices while the ride is in operation, please ensure the app has been started prior to loading, as use of the app is not permitted while the ride is in motion.

Be sure to know and understand the orientation of the cell phone to properly interpret the data. We suggest you practice using it before coming to the park to understand how the data is interpreted with different orientations. Depending on your level of understanding and familiarity using the app(s), you may want to use the absolute value feature that will allow you to see just the magnitude.

The use of cell phone accelerometers is not required to experience Amusement Park Science. The exciting curriculum provides other questions or investigation opportunities that can be incorporated with many of our rides without the use of these accelerometers.

Note: Using your cellphone on a field trip is your responsibility. Playland is not responsible for any lost or damaged items.

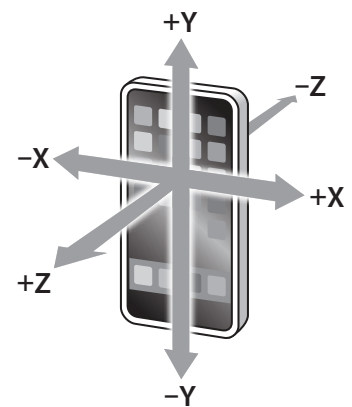

Table of Contents

| | | |
|------|-----|-----------------|
| page | i | Introduction |
| page | ii | Sample Timeline |
| page | iii | Site Map |

SECTION A MAKING MEASUREMENTS

| | | |
|------|-----|-----------------|
| page | A-1 | Time |
| page | A-1 | Distance |
| page | A-3 | Useful Formulae |

SECTION B CONSTRUCTING THE EQUIPMENT

| | | |
|------|-----|----------|
| page | B-1 | Astrolab |
|------|-----|----------|

SECTION C SCIENCE 8 WORKSHEETS

| | | |
|------|------|-------------------------------------|
| page | C-1 | A Brief History of Amusement Parks |
| page | C-6 | Estimation at the Amusement Park |
| page | C-7 | Physiology of Amusement Park Rides |
| page | C-8 | Coaster |
| page | C-11 | ThunderVolt |
| page | C-13 | Skybender |
| page | C-14 | Dizzy Drop |
| page | C-15 | Merry-Go-Round |
| page | C-16 | Hydraulics and Pneumatic Rides |
| page | C-18 | Calculating the Height of the Rides |
| page | C-19 | Graphing Height Above the Ground |
| page | C-21 | Nutrition at the Amusement Park |
| page | C-23 | First Nations Science |

Introduction

The accompanying materials have been divided into several sections: one with information concerning measurements, one containing information on instrument construction, and one with the ride worksheets. Teachers are given flexibility for its use but are reminded that this educational program is used by many schools.

We try to have consistency between schools' implementation by asking each teacher to remind their students that this is an educational event. A rule of thumb is to have each student or group of students complete 3 or 4 of the modules. That is a reasonable expectation for them and keeps them on task during the day. Schools that are wishing to use this event as a reward for "hard work" through the year and that do not intend to have their students working on this material are asked to make arrangements to visit Playland at another time.

Students *must* be using the following materials throughout the day:

1. Packet of activities
2. Pencil
3. Timing devices (digital watches with stopwatch mode are nice)
4. Calculator

Critical Safety Note

As hand-held devices are not permitted on amusement park rides, students may use accelerometer apps installed in advance on cell phones. During rides, phones must be securely stored in arm bands or hip packs.

Sample Timetable

Please adapt to fit your circumstances

Time Schedule

| | |
|--------------|--|
| 8:30 | Buses leave school |
| 9:15 | Arrive at Playland |
| 9:30 | Enter Playland Amphitheater for opening presentation |
| 9:45 – 10:00 | Opening Presentation at Playland Amphitheater |
| 10:00 | Gates to Playland open to admit students |
| 10:00 – 2:00 | Carry out pre-planned activities involving observations and measurements of selected aspects of the rides. Arrange a meeting time with your teacher for problems that arise or questions you have. |
| 2:00 | Playland closes and event ends |
| 2:15 | Board buses for return to school |
| 3:00 | Buses arrive back at school |

Things to Bring:

- Lunch (You will NOT be allowed to leave the park for lunch)
- Pencil
- Calculator (app on most phones)
- This assignment package!
- A watch or device with seconds and a stopwatch mode to record times on the rides

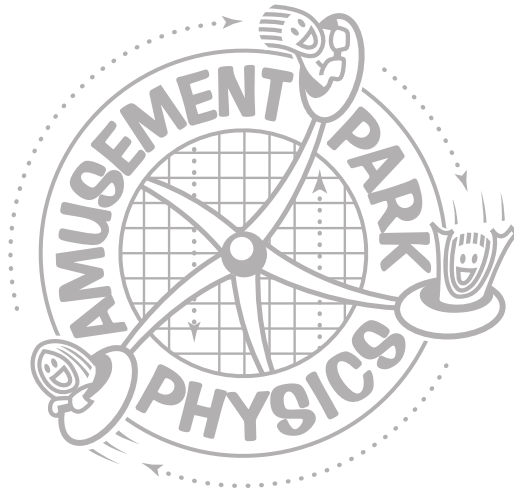

Section A

Making Measurements

page A-1 Time

page A-1 Distance

page A-3 Useful Formulae

Time

The times that are required to work out the problems can easily be measured by using a watch with a second hand or a digital watch with a stop watch mode. When measuring the period of a ride that involves harmonic or circular motion, measure the time for several repetitions of the motion. This will give a better estimate of the period of motion than just measuring one repetition. You may want to measure the time two or three times and then average them.

Distance

Since you cannot interfere with the normal operation of the rides, you will not be able to directly measure heights, diameters, etc. All but a few of the distances can be measured remotely using the following methods. They will give you a reasonable estimate. Try to keep consistent units, i.e. meters, centimeters, etc., to make calculations easier.

Pacing: Determine the length of your stride by walking at your normal rate over a measured distance. Divide the distance by the number of steps and you can get the average distance per step. Knowing this, you can pace off horizontal distances.

My pace = _____ m

Ride Structure: Distance estimates can be made by noting regularities in the structure of the ride. For example, tracks may have regularly spaced cross-members as shown in *figure a*. The distance d can be estimated, and by counting the number of cross members, distances along the track can be determined. This method can be used for both vertical and horizontal distances.

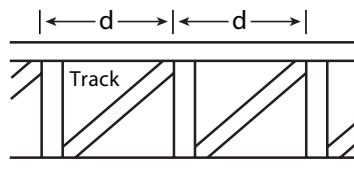

figure a

Triangulation: You can measure the height of a ride using a type of mathematics called trigonometry. Trigonometry is the study of the relationship among the sides and angles of triangles. These relationships are called trigonometric ratios. In this case, you'll use the tangent ratio.

Part One

1. Make an astrolabe using the procedure in Section B.

Part Two

Measure or estimate a distance that is 31 m from the base of the object you are measuring (such as the Hellevator).

Face the object, then look at the top of it sighting through the tube on the astrolabe. Without moving the position of the astrolabe, read the degrees where the string touches the astrolabe.

Use the chart below to approximate the height of the object. Interpolate between these data values for angle measurements that aren't multiples for five.

| Angle (in degrees) | Height of the Object (in metres) |
|--------------------|----------------------------------|
| 5 | 2.7 |
| 10 | 5.4 |
| 15 | 8.2 |
| 20 | 11.2 |
| 25 | 14.4 |
| 30 | 17.8 |
| 35 | 21.5 |
| 40 | 25.8 |
| 45 | 31.0 |
| 50 | 36.7 |
| 55 | 43.9 |
| 60 | 53.3 |

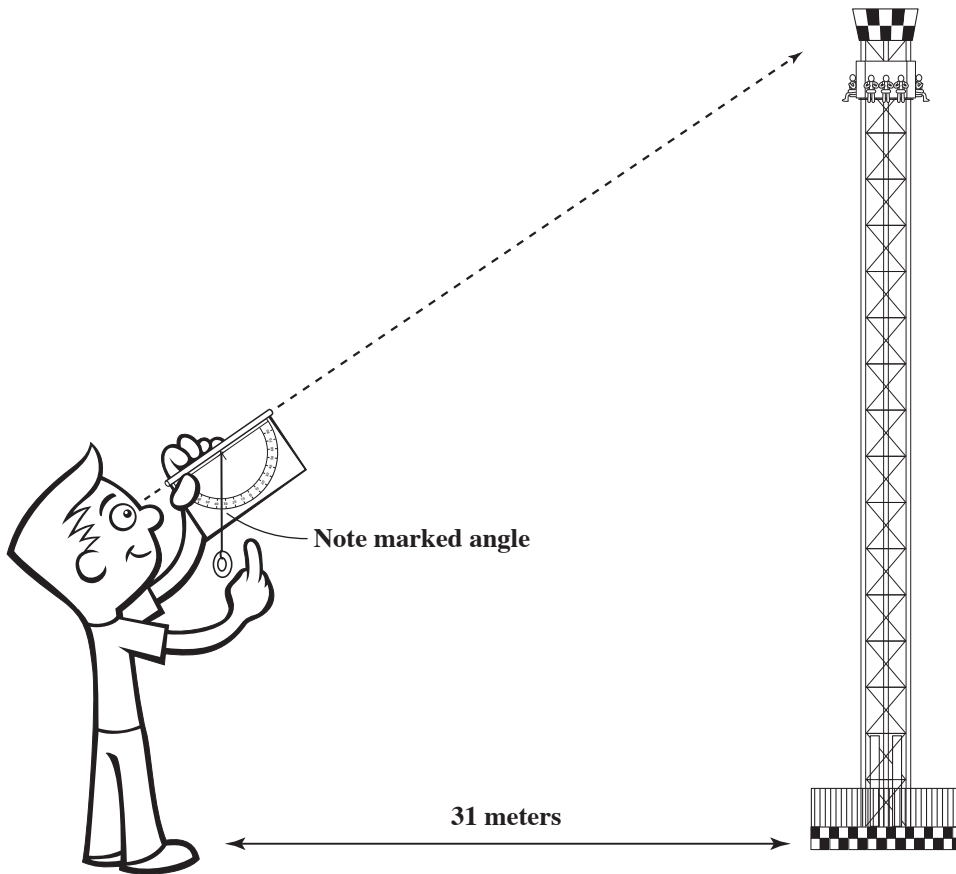

Useful Formulae

Circumference of a circle

$$C = 2\pi r \quad \pi = 3.14$$

$r = \text{radius of the circle}$

Example: What is the circumference of a circle with a radius of 10 m?

$$\begin{aligned} C &= 2\pi r \\ &= (2)(3.14)(10) \\ &= 62.8 \text{ meters} \end{aligned}$$

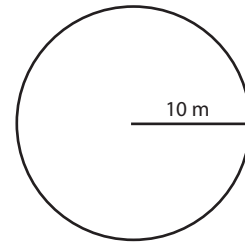
**Speed of an object in a straight line**

$$v = \frac{d}{t} \quad \text{Speed} = \frac{(\text{distance travelled})}{(\text{time for the trip})}$$

Example: What is the speed of a roller coaster if it takes 53 seconds to make a trip of 700m?

$$\begin{aligned} v &= \frac{d}{t} \\ &= \frac{700 \text{ m}}{53 \text{ sec}} \\ &= 13.2 \frac{\text{m}}{\text{sec}} \end{aligned}$$

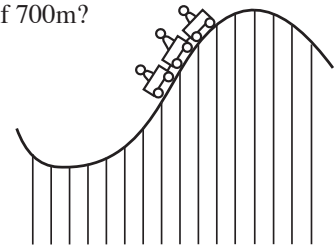
**Speed of an object in a circle**

$$v = \frac{2\pi r}{t} \quad \text{Speed} = \frac{(\text{distance travelled})}{(\text{time for the trip})} \quad (t = \text{time for one revolution})$$

Example: What is the speed of a car around a ride that has a 10m radius and takes 6.1 sec to make one revolution?

$$\begin{aligned} v &= \frac{2\pi r}{t} \\ &= \frac{2(3.14)(10 \text{ m})}{6.1 \text{ s}} \\ &= 10.3 \frac{\text{m}}{\text{sec}} \end{aligned}$$

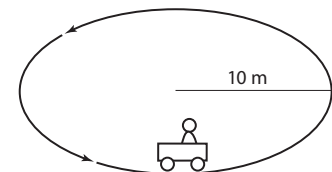

$t = 6.1 \text{ s}$

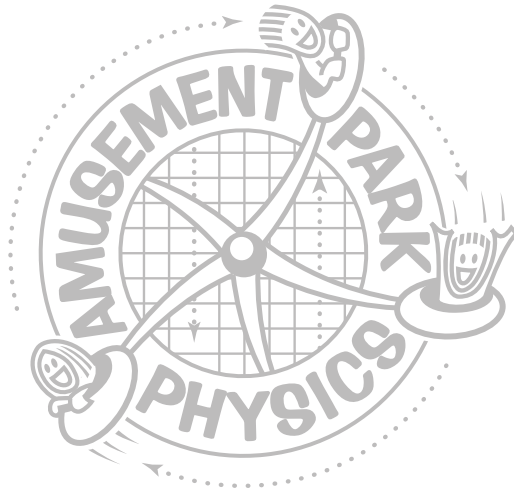

Section B

Constructing The Equipment

ASTROLAB

Triangulation Instrument and Accelerometer

1. Cut out the Astrolab.
2. Fold the top section over a pencil and roll it down to the heavy double line to make a sighting tube.
3. Tape the rolled paper tube closed and then let the pencil slide out.
4. Glue the Astrolab to a 8" x 5" index card and trim.
5. Take about 20 cm of heavy thread and tie one end to a weight such as a key or washer. Tie the other end through the hole at the top of the Astrolab.
6. Let the thread hang free. The angle it marks is the angular height of an object seen through the tube.

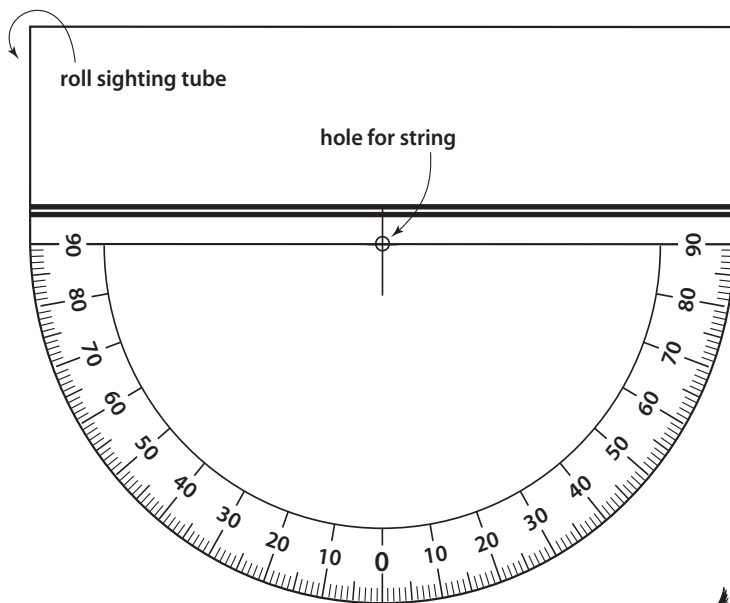

For instance:

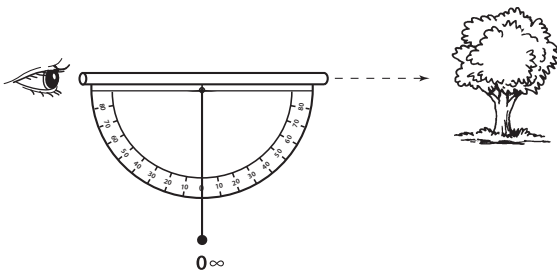

An object on the horizon has an angular height of 0 degrees.

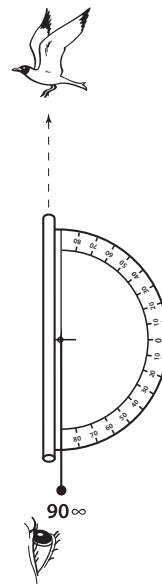

An object directly overhead has an angular height of 90 degrees.

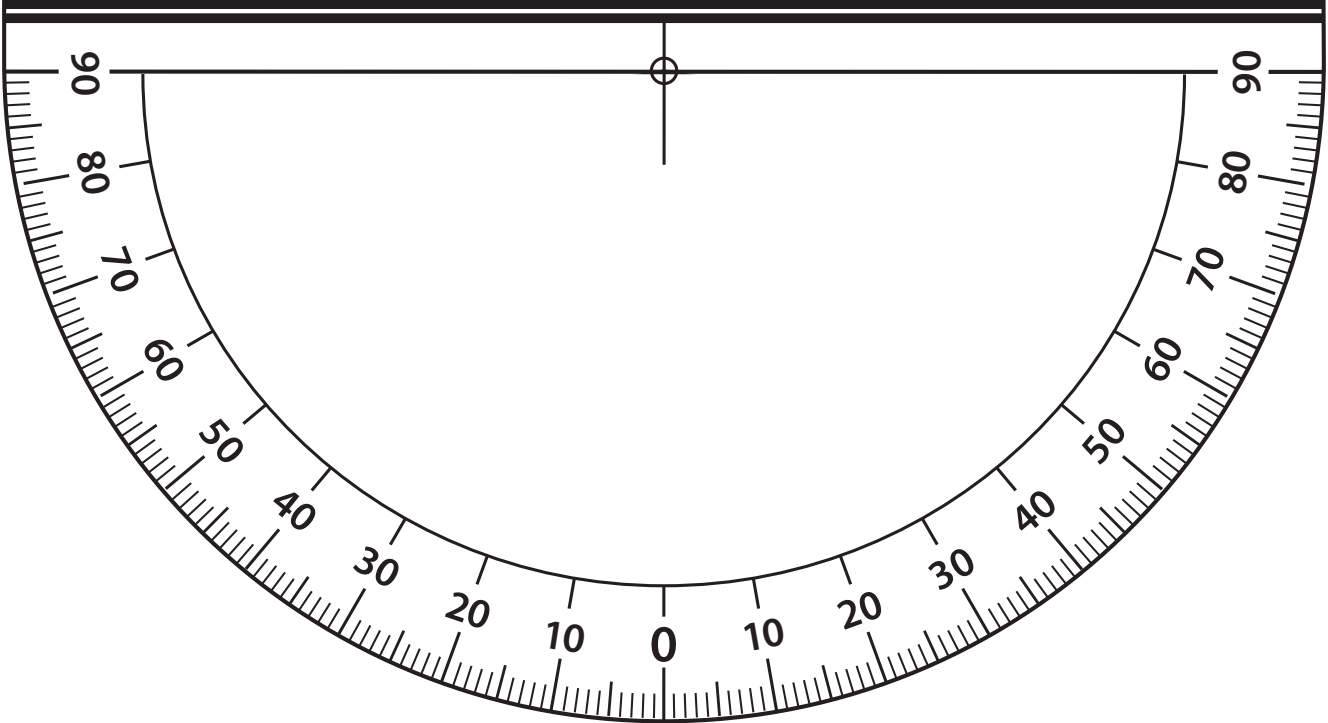

Amusement Park Physics

Section B • Constructing the Equipment

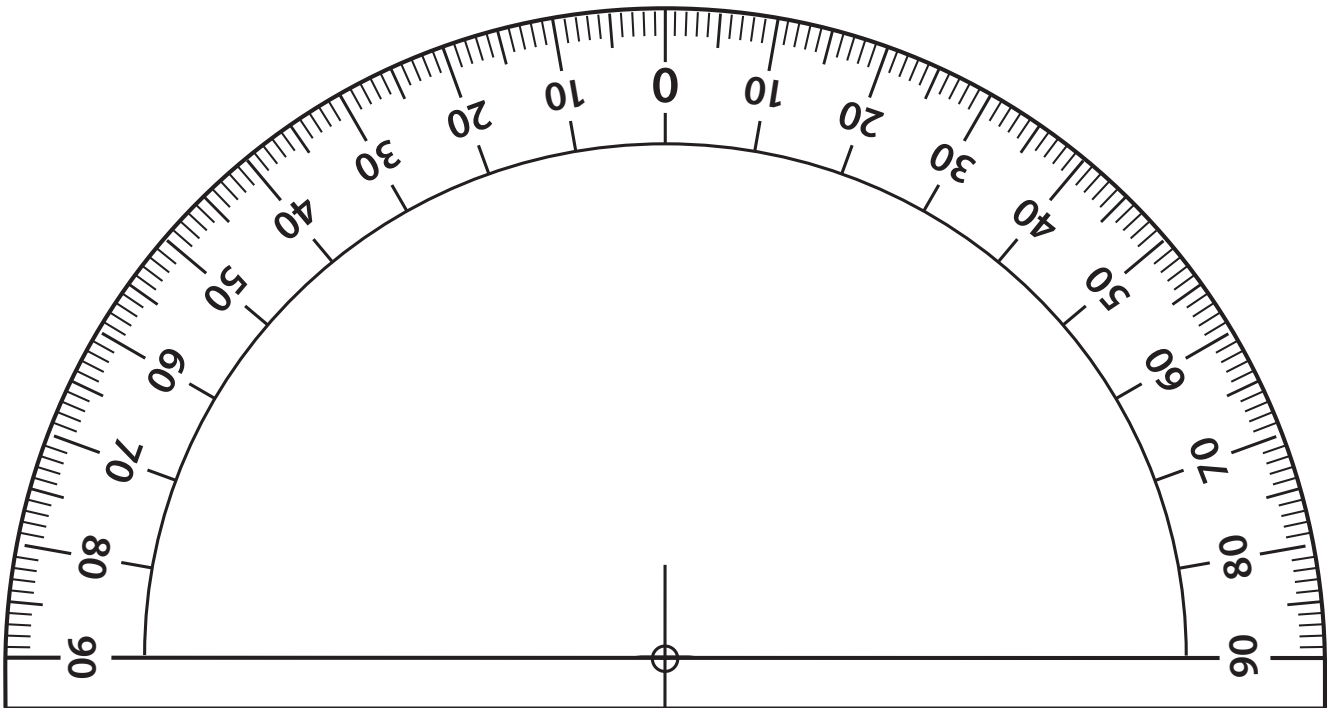

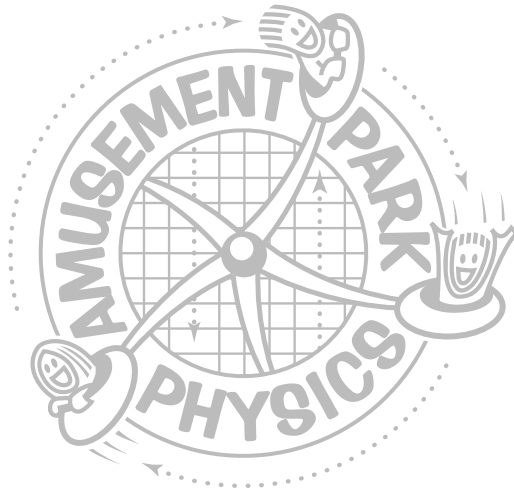

Section C

Science 8 Worksheets

| | |
|-----------|-------------------------------------|
| page C-1 | A Brief History of Amusement Parks |
| page C-6 | Estimation at the Amusement Park |
| page C-7 | Physiology of Amusement Park Rides |
| page C-8 | Coaster |
| page C-11 | ThunderVolt |
| page C-13 | Skybender |
| page C-14 | Dizzy Drop |
| page C-15 | Merry-Go-Round |
| page C-16 | Hydraulics and Pneumatic Rides |
| page C-18 | Calculating the Height of the Rides |
| page C-19 | Graphing Height Above the Ground |
| page C-21 | Nutrition at the Amusement Park |
| page C-23 | First Nations Science |

This activity can also be used as an alternative assignment for students who do not attend the Amusement Park Science field trip.

A Brief History of Amusement Parks

A common question arises when visiting an amusement park – why would anyone invent such a thing? When did the rides first show up? The parks themselves evolved from earlier city parks and gardens where people could walk, talk and eat. Even Coney Island, in the United States, was a popular vacation destination at the time of the Civil War, long before it became an amusement park.

Roller Coasters

Current amusement park rides have their origins in several places. For the roller coaster, the short answer is that the Russians started them in the 15th century. They built ice slides in St. Petersburg that were the precursors to modern roller coasters. A seventy-foot wooden frame was packed with snow, watered down to create ice, with sand added near the end of the run to stop the “sleds.” Originally, sleds were made from two-foot blocks of ice with a carved out place that was filled with straw for insulation. The trip was so scary that passengers sometimes had to have a guide for the trip. The passenger would sit in the guide’s lap and together they would speed down the hill. When the ride was finished, the passenger had to carry the sled back to the top of the hill.

From this early beginning, other gravity powered rides, sometimes known as Russian Mountains, evolved in Europe and then in the United States. LaMarcus Thompson, called by some the “father of gravity,” created the first roller coaster at Coney Island in 1884. His “Scenic Railway,” with ten people per coaster car, quickly became popular. At a nickel a ride, the railway took in \$600 a day and paid itself off in three weeks. The ride was tame by today’s standards. As their name implies, it was a way to ride on the beach and see the sights. The riders rode sideways to better see the ocean and rolled at the death defying speed of six miles per hour! But it was popular, and by 1888 Thompson had built nearly fifty coasters in North America and Europe.

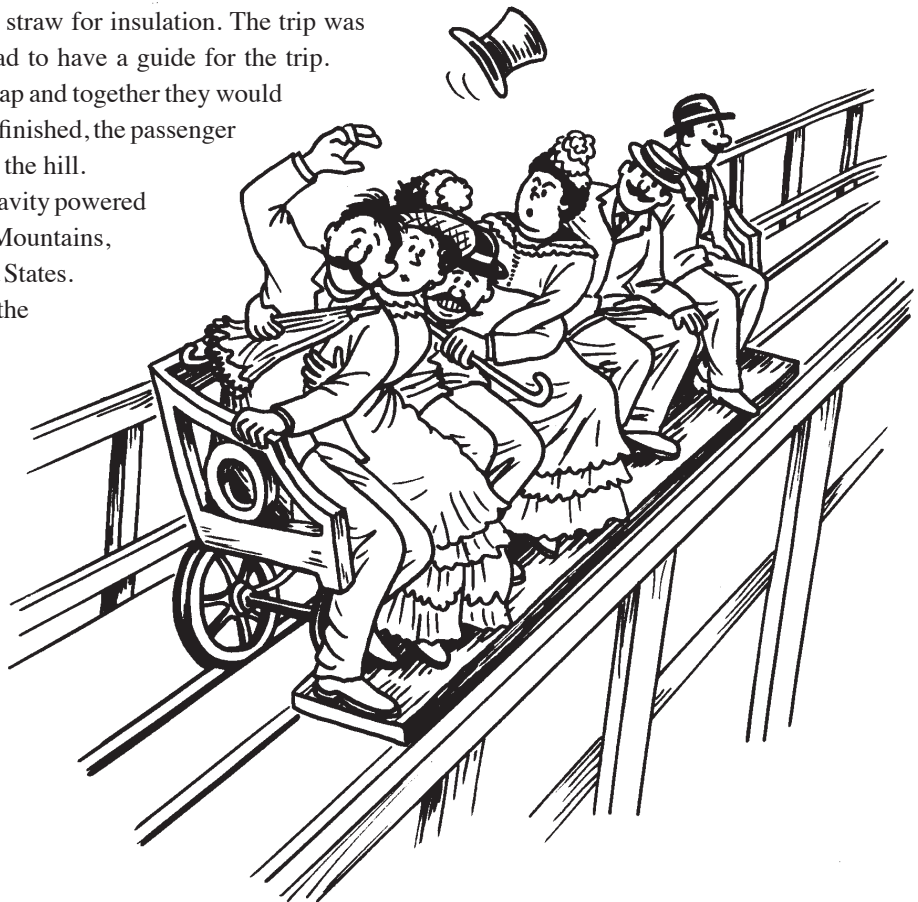

Others quickly entered the coaster market and the competition led to design improvements. Charles Alcock invented the first oval track coaster that returned passengers non-stop to their starting point. Phillip Hinckle's coasters added a chain elevator system that carried the loaded cars up the first hill. This advancement sparked the development of the giant coasters that still dominate today's amusement parks.

In further innovations, Thompson linked two cars together forming the first coaster train, which doubled rider capacity and made a better financial investment. Between 1884 and 1887, Thompson patented thirty improvements to the coaster ride. He also was the first to construct a tunnel over a portion of the track to create frightening darkness. Nearly a hundred years later, Walt Disney would exploit this same sudden darkness in Disneyland's Matterhorn. Space Mountain would take this coaster format to its ultimate by having riders in total darkness.

Demand for steeper hills, faster speed and increased passenger capacity continued to grow. In the early 1900s John Miller designed and built the biggest coasters with higher hills, steeper inclines and more terrifying speeds. Along with these bigger coasters came the need for more safety devices and Miller invented "undertrack wheels" that prevented the cars from jumping off the tracks while speeding over the tops of hills.

The Roaring Twenties, with its drive for reckless excitement, ushered in the Golden Age of the roller coaster. The scream machines of the period reflected the culture, when people sought sensual thrills and the automobile gave them a taste for speed. Coasters increased in size and number. By one estimate, North America had at least 1,500 of them before the coaster's popularity declined during the Depression. As money became scarce and later, during World War 2, as wood and rubber were rationed, most roller coasters slowly became silent, rotting wooden dinosaurs.

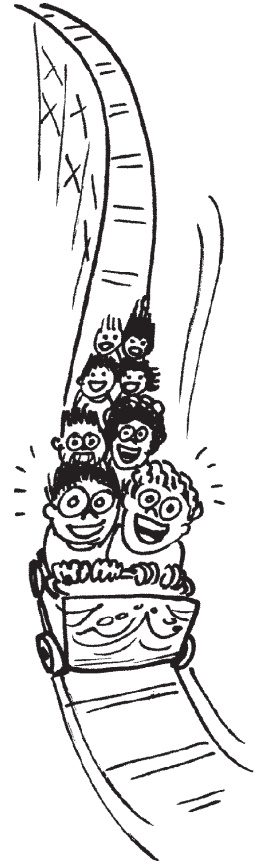

The Merry-Go-Round

The Merry-Go-Round, or Carousel, has its origins in 17th century England. Large wooden wheels with carved wooden horses attached to their outsides were turned by servants so that young lords could practice their jousting techniques. As the young lords rode around, they carried lances and tried to spear stationary rings. This is not too different from later carousel rides in which riders tried to grab brass rings as their horses moved in a circle.

In the 19th century, Frederick Savage, a machinist worker in King's Lynn, England, put a steam engine on the carousel. At about the same time, in the United States, Eliphert Scripture of Green Point, New York, attached the rear of the horses to a pivot and moved the front of the horse up and down to create a riding motion. Popularity boomed when carver Salvatore Cernigliaro applied his marvellous craft to carousel design and greatly increased the beauty of the ride. He carved carousel animals of all kinds and added jewels and colour. The most popular of his creations were his galloping horses with their flowing manes. Many of his carved and decorated horses are now being restored to their original beauty.

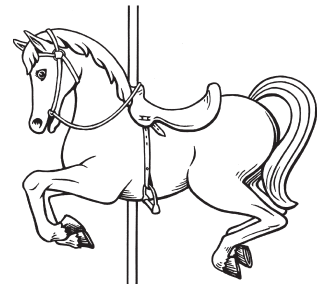

Ferris Wheel

Of prime importance in the development of amusement parks was the creation of the Ferris wheel. The first "Ferris" wheel, built for the 1893 Chicago Columbian Exposition, was envisioned by George Washington Gale Ferris. Ferris's wheel was modelled after the structural principles of the bicycle wheel. This first wheel was enormous – nearly 300 feet

tall and 30 feet wide. It had thirty-six pendulum cars, each able to hold sixty passengers. The axle of the incredible structure was a manufacturing feat without parallel – the largest single piece of steel ever forged to date. Produced by the Bethlehem Iron Company, the axle was over forty-five feet long, almost three feet in diameter and weighed forty-five tons. The entire structure weighed 1,200 tons, was driven by two 1,000 horsepower reversible engines and could carry 2,160 riders.

No steel company could handle the manufacturing job alone. Ferris had to contract with a dozen companies to produce the bars, trusses and girders, which were meticulously planned to fit together like giant Tinkertoys when assembled at the site.

The construction cost of the original the Ferris Wheel was nearly \$350,000 and the technology to build it had never been used before. Thus, investors were difficult to find at first. Nevertheless, Ferris pulled the deal off and by the closing of the Chicago Exposition, 1,453,611 customers had paid the exorbitant fee of 50¢ for a 20-minute ride. Ferris showed the world that technology could be used on a grand scale simply for fun. In 2007, Playland added a 50' tall Ferris Wheel.

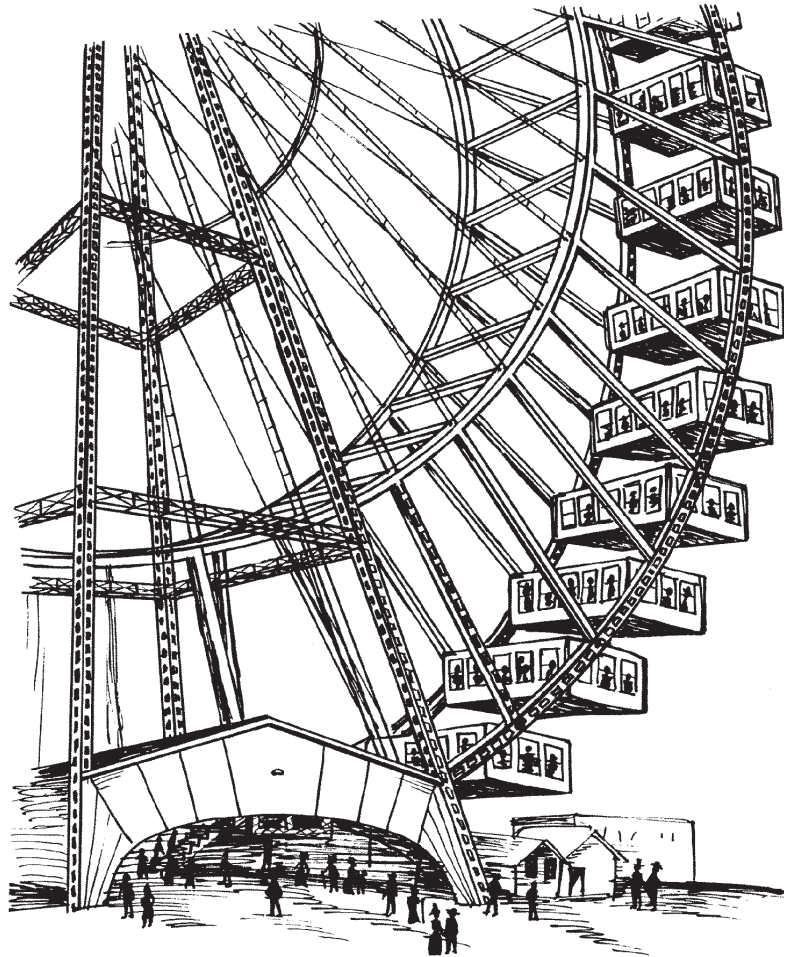

Modern Amusement Parks

Few things have managed to survive changing times and tastes like amusement parks. With the success of the 1893 Columbian Exposition, the modern concept of the amusement park began developing at Coney Island in Brooklyn, New York. By the early 1900s many major cities in North America could boast of one or more amusement parks with a carousel, a Ferris wheel, a penny arcade and fireworks displays. These parks also emphasized band concerts and other entertainment. By 1919 over 1,500 amusement parks existed in North America.

This spectacular growth began to decline after World War I, as did all outdoor entertainment. After the stock market crash in 1929, people didn't have any extra money to spend in amusement parks. In the 1930s the Depression brought a few new patrons seeking escape from their dreary lives, but this only slowed the decline. Popularity continued to decline after World War 2.

The salvation of the amusement park came in its mutation, the theme park. The theme park was originally the brain child of Walt Disney. The notion of organizing amusement parks around a theme offered an entirely new gimmick. Initially, people scoffed at Disney and he had a difficult time financing the project. He struck an unusual deal that tied his theme park to newly created television shows, the Mickey Mouse Club and The Wonderful World of Disney. Disneyland the theme park and Disney's television shows both took off in popularity and amusement parks have never been the same since.

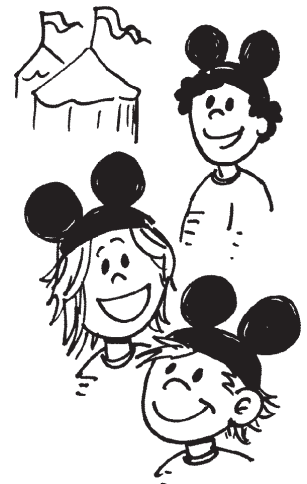

Playland Amusement Park

Although Playland Amusement Park has been at its current location on Hastings Street since the Pacific National Exhibition opened in 1958, its origins go back much further. The first proposals for a regional exhibition that would provide entertainment for local residents and a forum for agricultural excellence came in 1890.

The Vancouver Exhibition Association was formed in 1907 by local businessmen, and in 1910 Vancouver held its first exhibition. This inaugural exhibition was opened by Sir Wilfrid Laurier, prime minister of Canada, and Sir Robert Baden-Powell, founder of the Boy Scout movement. In addition to the entertainment that was provided daily at the exhibition, there was an extravaganza of games, sideshows and rides.

By 1915, a scenic railway (roller coaster) and a merry-go-round had been permanently added to the site, just south of the race track, with other rides brought in during the exhibition each year. To increase revenue for the exhibition, the amusement area was kept open in the summer months and was named “Happyland.” Happyland increased in popularity in the 1920s, along with other amusement parks in North America. However, it too suffered through the Depression. Its roller coaster, the Big Dipper, was once a very popular ride, but had to be demolished for safety reasons after amusement park revenues declined.

After World War II, the exhibition association decided to revitalize the summer event and renamed it the Pacific National Exhibition (PNE), symbolizing its provincial and national nature. With its broader scope, the exhibition expanded and attendance soared. Happyland continued to be open in the summer months, operated by various amusement park companies.

In 1955, the PNE took control of Happyland’s management and two years later, in a comprehensive development plan, relocated the amusement area to its current location and renamed it Playland. The centrepiece for Playland has always been its roller coaster, still ranked as one of the best wooden coasters by the American Roller Coasters Enthusiasts organization.

Playland added three new rides in 2000, including the hair-raising Hellelevator in which riders experience the “beyond free-fall” floating negative G force, Hell’s Gate, where riders loop within loops at 30 km/h and risk getting drenched in the water fountain, and Revelation, an extra price ride, which is a 160 ft. (50 meter) tall spinning propeller ride which is among the fastest, most exhilarating extreme rides in the world.

In 2004, Playland added The Kettle Creek Mine Coaster, where adults and children alike can experience the thrills and excitement of a mine car adventure through a rough and rugged terrain. In 2006, Playland added the Gladiator and Break Dance, both rides involve two rotating axes with thrilling spins. In 2011, Playland added the exciting new ride Atmosfear. It’s like riding on the wave swinger at 60 m off the ground, giving you a great view of Vancouver if you’re brave enough to open your eyes! In 2022, Playland added Skybender, spinning riders in circles at 65 km/h, making it the fastest single-rider ride in Canada! In 2024, Playland added Canada’s fastest launch coaster, ThunderVolt!

The Pacific National Exhibition is over 108 years old! Experience thrill rides and excitement at Playland on weekends starting in late April until late September and daily from July until August. The Fair at the PNE brings in even more rides as well as 800 free-with-admission shows, exhibits and attractions from August to September. Fright Nights is back to haunt you daily in October... come if you dare! Soccer is also home to the PNE – come enjoy soccer *and* football at the stadium at Empire Field.



Curriculum Integration Activities

- 1 Create a time line which represents the history of the amusement park.
- 2 Discuss the historical event which had an effect on the amusement park's evolution (eg. the Roaring 20s, the Great Depression, World War 2, etc.).
- 3 Imagine that you are a newspaper editor in 1910. Write an editorial which supports or criticizes the "current rage" for roller coasters.
- 4 Brainstorm a list of modern "thrill" sports (eg. bungee jumping, parasailing, skydiving). Discuss the ways in which early amusement park rides were similar in their appeal to thrill seekers.
- 5 Create a 1920s style poster to advertise a "new, exciting" ride at Happyland. It could publicize the Big Dipper, their roller coaster.
- 6 After you return from your visit to Playland, write an article for your school newspaper about your experience. One technique used to organize a newspaper article is called the 5Ws – Who, What, When, Where, and Why. Use it to cover the main points of your field trip. Be sure to include several things you learned and what part of the field trip you most enjoyed.

Estimation at the Amusement Park

One skill that is important in science is *estimation*. An estimation gives you an approximate answer before you solve a problem. This estimation will tell you if your answer is reasonable. Try the following activities and sharpen your estimation skills. For each question, give your estimation *and the reasoning you used* to obtain that estimation. Remember, an estimation is not just a guess.

Questions

1 How tall is the highest hill on the Coaster?

2 What is the average speed of the Coaster for a complete trip?

3 How many swings does the Pirate Ship ride make during its operation?

4 How many hot dogs do all the concession stands combined sell during one day at Playland?

5 How many people are at Playland today?

Physiology of Amusement Park Rides

List five different rides below. For each, measure your pulse rate and breathing rate before and after the ride. You can take your pulse by lightly placing your fingertips on the inside of your wrist, near your thumb, or by placing your fingertips behind your ear. Record any symptoms that you experienced by placing numbers of those appropriate symptoms from the list beside the name of the ride.

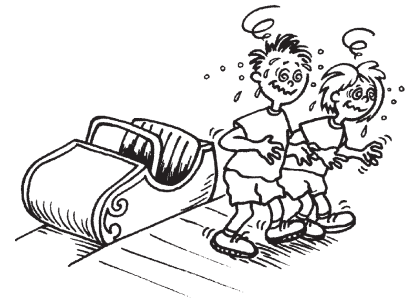

Symptoms:

- | | | |
|-------------------|------------------------|-------------------------|
| 1. dry mouth | 5. cold hands/feet | 9. upset stomach |
| 2. dizziness | 6. enlarged eye pupils | 10. fast breathing |
| 3. tense muscles | 7. trembling | 11. stomach butterflies |
| 4. unable to move | 8. sweaty hands | 12. other (explain) |

| Ride | Pulse Rate | | Breathing Rate | | Symptoms | |
|------|---------------|--------------|----------------|--------------|---------------|--------------|
| | <i>before</i> | <i>after</i> | <i>before</i> | <i>after</i> | <i>before</i> | <i>after</i> |
| | | | | | | |
| | | | | | | |
| | | | | | | |
| | | | | | | |
| | | | | | | |

1 Explain any differences you found in heart rate or breathing before and after each ride. Why do you think these changes happened?

2 Use your knowledge of the circulatory system to follow a drop of blood through your heart as your heart rate increases. What effect does this increase have on blood flow to your body?

3 Explain the connection between the circulatory system and the respiratory system. Why does an increase in the rate of one usually cause an increase in the other?

Coaster

The roller coaster was one of the first amusement park rides invented. They were originally made of wood and the coaster cars rode on steel wheels. Later versions followed paths of steels and rolled on air-filled tires. Basically, they all work for the same reasons. They operate because of gravity. The park charges for the energy it uses to take you to the top of the first hill and gravity gives you the rest of the ride for free. Of course, the park also ensures that you get safely back to the starting point.

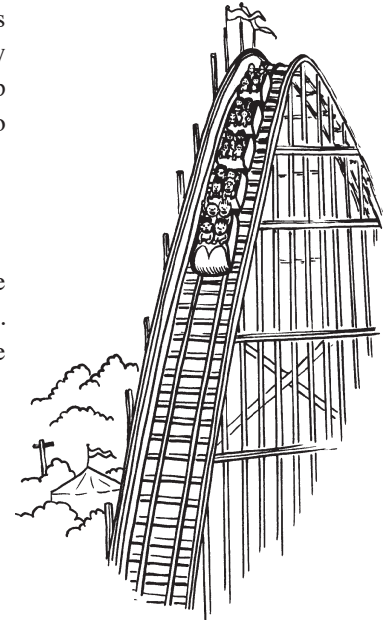

Procedure

As you ride the Coaster, try to experience the ride as you would any other science experiment. You are the experiment. Note where you feel increased and decreased forces. Use your accelerometer to measure the forces in several parts of the ride and complete the data section below.

Data

Length of track 1,001 m

How many slopes are involved in this ride? _____

How many turns are involved in this ride? _____

Time for one trip: _____ sec

Pre-Ride Questions

1 Predict when the ride will be at its fastest?

2 What do you think will happen to your body when you go around a turn?

3 Which hill is the tallest on the roller coaster? Why is that?

Questions

1 What happens to the size of the hills during the ride? Why?

2 Are you moving faster or slower when you are at the top of a hill? Why?

3 Are you moving faster or slower when you are at the bottom of a hill? Why?

4 As you go up a hill, do you gain or lose speed? Why?

5 As you go down a hill, do you gain or lose speed? Why?

6 As you go up a hill, do you feel heavier, lighter or the same as you usually do? Why?

7 As you go down a hill, do you feel heavier, lighter, or the same as you usually do? Why?

8 When you are in a turn, are you pushed inward or outward? Why?

9 Are the tracks tilted inward, outward or are they flat on curves? Why?

10 How fast do you think the ride goes?

11 Calculate the average speed of the ride.

Procedure 2 and Questions

Using the diagram below, pick the best place on the ride for each description. Put the number in the space beside the description. You may use the numbers more than once and may place more than one number by each description.

- Accelerating (speeding up) _____
- Decelerating (slowing down) _____
- Banked curve _____
- Centripetal force _____
- Weightless zone _____
- Greatest speed _____
- Slowest speed _____
- Most potential (stored) energy _____
- Most kinetic (movement) energy _____
- Backward leaning zone _____
- Forward leaning zone _____

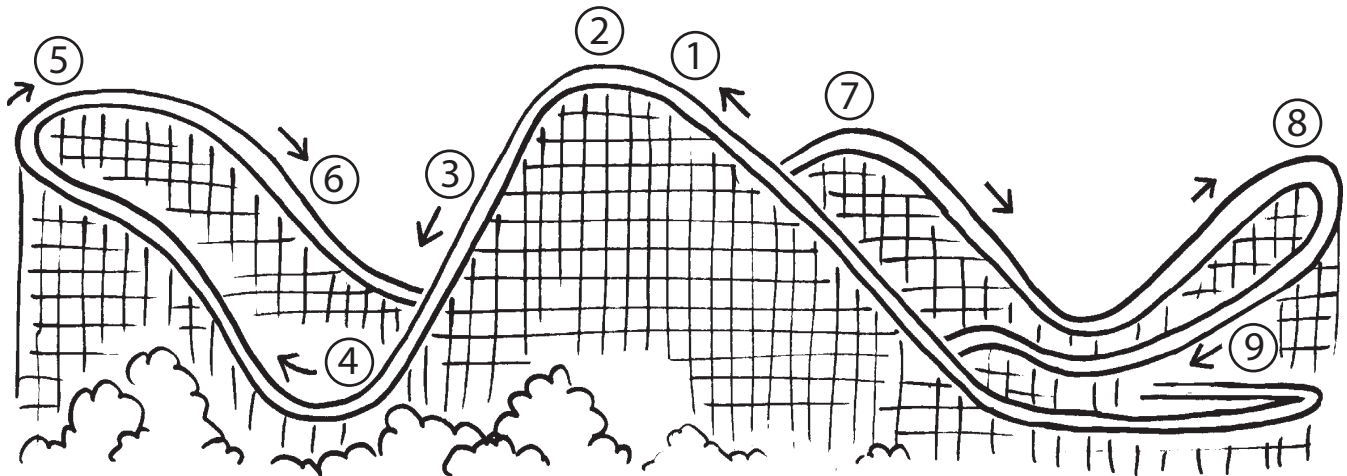

ThunderVolt

The ThunderVolt is Canada’s newest and fastest electric launch coaster! The ThunderVolt experience carries 12 passengers at a time through a supernatural environment with extraordinary animals, graphics and lighting that pulses as the ride system charges, leading up to its launch. The 3-car train blasts off with 1.3 Gs of acceleration through an illuminated tunnel, up a steep incline before a thrilling drop.

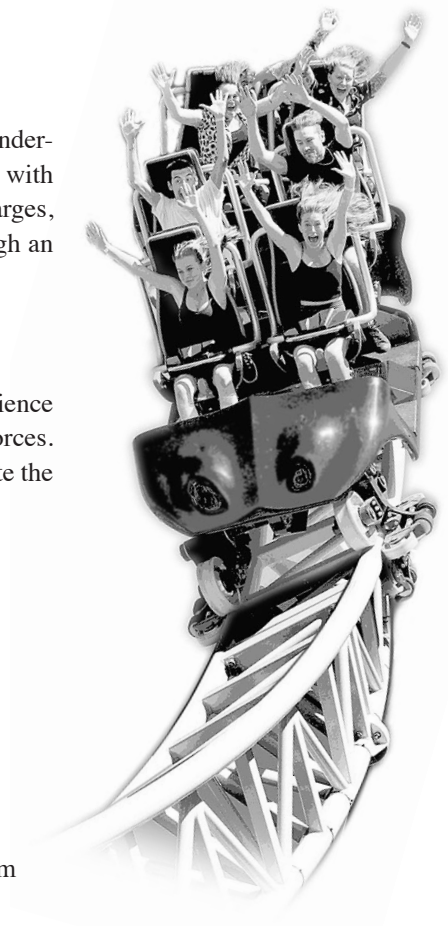

Procedure

As you ride the ThunderVolt, try to experience the ride as you would any other science experiment. You are the experiment. Note where you feel increased and decreased forces. Use your accelerometer to measure the forces in several parts of the ride and complete the data section below.

Data

Mass of the car(s) 6,110 kg
 Estimate the height of the first hill _____ m
 Estimate the time it takes for the cars to accelerate _____ sec

Pre-Ride Questions

1 After watching this ride a few times, describe how ThunderVolt is different from the wooden roller coaster.

2 Before going on the ride, do you think that the forces and sensations you feel will be like the wooden roller coaster or completely different? Explain your answer.

Questions

3 Describe the forces you felt when launched at the start of the ride.

4 When riding ThunderVolt, where do you feel the heaviest and where do you feel the lightest?

5 The ThunderVolt ride uses electromagnetism to make it accelerate so quickly.
How do you think it works?

Skybender

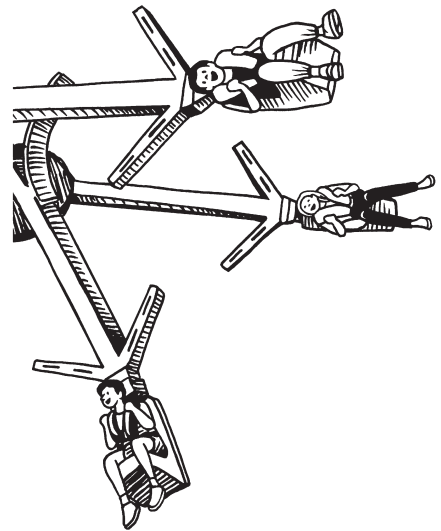

Data

Estimated distance from centre of rotation to seat (when in the rest position) _____ m

Estimated distance from centre of rotation to seat (in extended position) _____ m

Time for one revolution of the ride at max speed _____ sec

Questions

1 Describe the sensations that you felt on the ride, including what happened as the ride increased in speed.

2 Where do you feel the heaviest and where do you feel the lightest?

3 Estimate how fast you think you go at maximum speed?

4 Calculate the average speed of the rider as they move in a circle at maximum speed. (Circumference / time for 1 rotation)

5 Compare your answers for questions 3 and 4 and explain any difference.

Challenge Question

6 Based on what you know about speed and how you felt on the ride, are you going faster at the top of the extension or the bottom? *Hint: Think about change in the radius.*

Dizzy Drop

The Dizzy Drop is like the Hellevator but scaled down. Don't let its smaller size fool you. Even though it's not as tall, it can still cause you to grip the safety bar a little tighter.

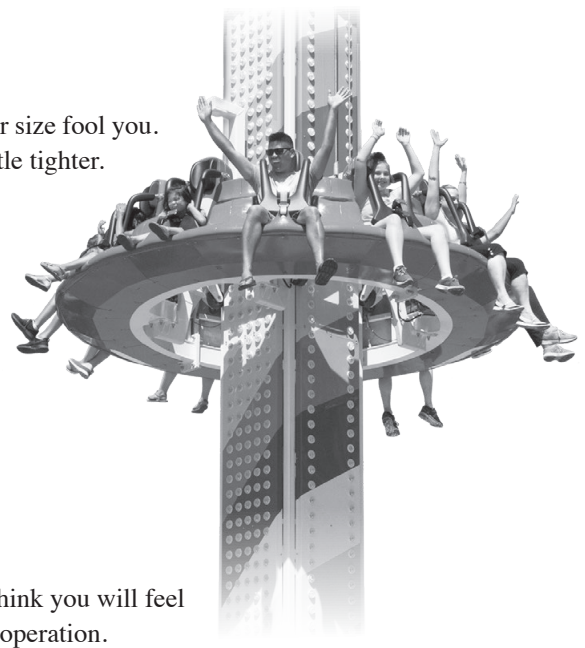

Data

Estimate the height of the ride _____ m
 Ride time 90 seconds
 Direction of travel up and down
 Vertical speed max deceleration 2.5 g

Pre-Ride Question

- 1 Watch the complete ride a couple of times and write down how you think you will feel before, during and after the ride or at specific times during the ride's operation.

Questions

- 2 After the ride, describe the forces you felt when the ride drops and goes back up.

- 3 Compare the forces you felt on Dizzy Drop with two other rides you experienced today at Playland. How are they similar and different.

- 4 Using the Astrolab and the information on page A-2 of this booklet, calculate the height of Dizzy Drop. Was it close to your estimation in the Data section above?

- 5 Using your answer from number 4, estimate the biggest drop (in metres) a rider experiences when on Dizzy Drop.

Merry-Go-Round

A timeless classic, the Merry-Go-Round is also known as a Carousel. Riders are captivated by the painted horses and classical carnival music. Have a seat on your favourite horse and enjoy a ride that has been around since the 17th Century.

Newton's Three Laws of Motion are important on the centripetal force rides such as the Merry-Go-Round and other rides that go in a circle. Centripetal force causes you to feel like you are being thrown to the side of a ride as it moves in a circle.

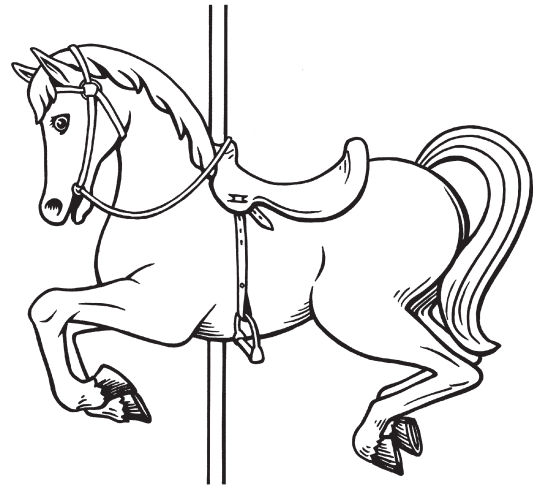

Data

| | |
|--|------------|
| Ride time | 90 seconds |
| Distance from centre of ride to the edge of the platform | 3.2 m |

Questions

- 1 When riding, does your body feel like it's moving inwards or outwards?

- 2 Do all the animals on the ride go up and down at the same time? Why do you think that is?

- 3 Ride the Merry-Go-Round once sitting on a horse on the outside of the ride and then ride again with a horse on the inside. Describe any differences or experiences you noticed.

- 4 Describe the difference in how you feel when the ride is moving up and moving down.

- 5 What do you think the Merry-Go-Round would feel like if the ride speed was increased? How would this change the forces you experience on the ride? Describe.

Hydraulics and Pneumatic Rides

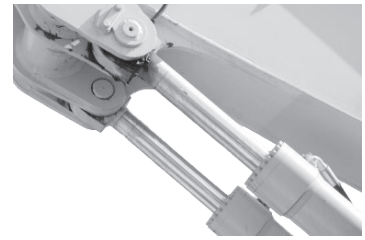

Constructed fluid systems are a part of several Playland rides. Both hydraulic (liquid) and pneumatic (air) systems are used in several ways. Your task in this activity is to analyze one of the rides below and describe how hydraulics or pneumatics is used.

Choose one of the following rides to investigate:

- Hellevator
- Hell's Gate
- Cedar Creek Log Flume
- Enterprise
- Gladiator

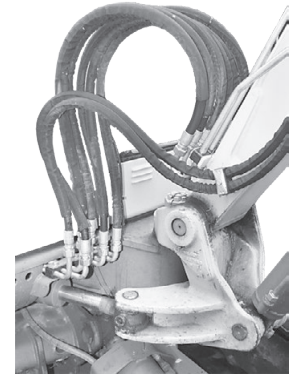

Questions *Answer only the questions that apply to your ride.*

1 Ride you investigated: _____

2 Where is a hydraulic system used in the ride?

3 Describe how the hydraulic system works.

4 Where is a pneumatic system used in the ride?

5 How would it change the ride if the hydraulic system on the ride was replaced with a pneumatic one, or vice versa? What problems would the change cause the ride operation?

Calculating the Height of the Rides

One way to calculate the height of a ride is by using a type of mathematics called trigonometry. Trigonometry is the study of the relationship among the sides and angles of triangles. These relationships are called trigonometric ratios. In this case, you'll use the tangent ratio.

Procedure

- 1 Measure or estimate a distance that is 31 m from the base of the object you are measuring (such as the Hellevator).
- 2 Face the object, then look at the top of it sighting through the tube on the astrolabe. Instructions for making your astrolabe are in Section B.
- 3 Without moving the position of the astrolabe, read the degrees where the string touches the astrolabe.
- 4 Use the chart below to approximate the height of the object. Interpolate between these data values for angle measurements that aren't multiples for five.
- 5 Remember that there are other ways to measure heights and distances. Refer to **Section A** for more ideas.

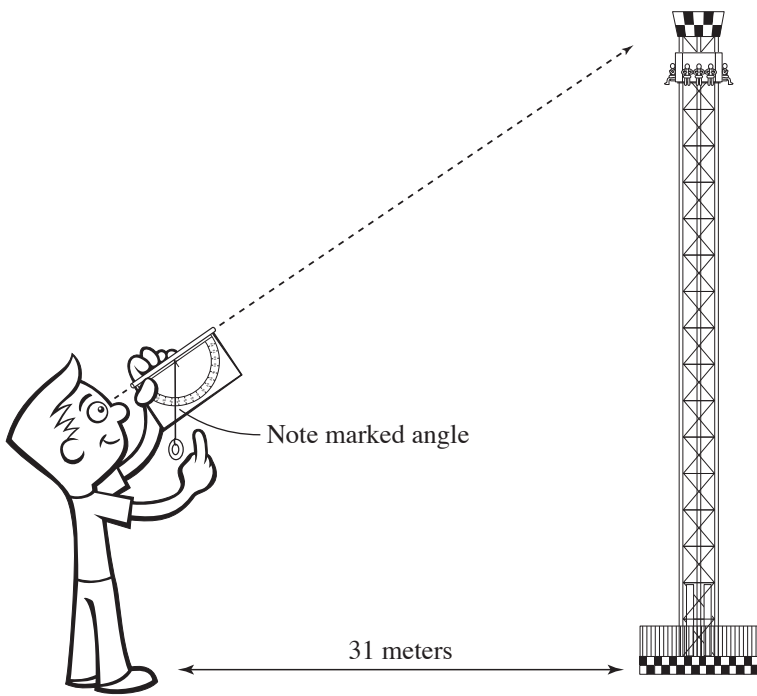

| Angle (in degrees) | Height of the Object (in metres) |
|--------------------|----------------------------------|
| 5 | 2.7 |
| 10 | 5.4 |
| 15 | 8.2 |
| 20 | 11.2 |
| 25 | 14.4 |
| 30 | 17.8 |
| 35 | 21.5 |
| 40 | 25.8 |
| 45 | 31.0 |
| 50 | 36.7 |
| 55 | 43.9 |
| 60 | 53.3 |

Data

Find the height of the following rides using the astrolabe or pacing.

| Ride and Location | Astrolabe Reading (if used) (in degrees) | Estimated Height or Distance (in m) |
|---------------------------------------|--|-------------------------------------|
| First hill on the Coaster | | |
| Top of the Revelation | | |
| Height of the Hellevator | | |
| Circumference of the Enterprise | | |
| Length of the first hill on the Flume | | |

Graphing Height Above the Ground

Graph height vs. time

For this activity, you are going to create a graph of height vs. time for one of the rides at Playland.

Procedure

- 1 Select one of these rides to collect data: Hells Gate, Hellevator, Revelation, Enterprise, Atmosfear or Ferris Wheel. List your choice on the line above the Data Chart.
- 2 List the places where you want to obtain data points and write them on first column of the Data Chart.
- 3 Use your astrolabe or other methods to determine the height of the several places on the ride. Record the heights on the chart next to their location.
- 4 Estimate the height of the remaining places on the ride. You can get a good estimate by comparing these points to the places you calculated in Step 3. Record these heights on the chart.
- 5 Time when the ride passes each of these places on the ride you have selected. Begin with time = 0 when the ride starts. Record these times in the third column of the Data Chart.

Data

Ride selected: _____

Data Chart

| Where on Ride | Height (m) | Time (s) |
|----------------------|------------|----------|
| example: ride starts | 1 m | 0 s |
| | | |
| | | |
| | | |
| | | |
| | | |
| | | |

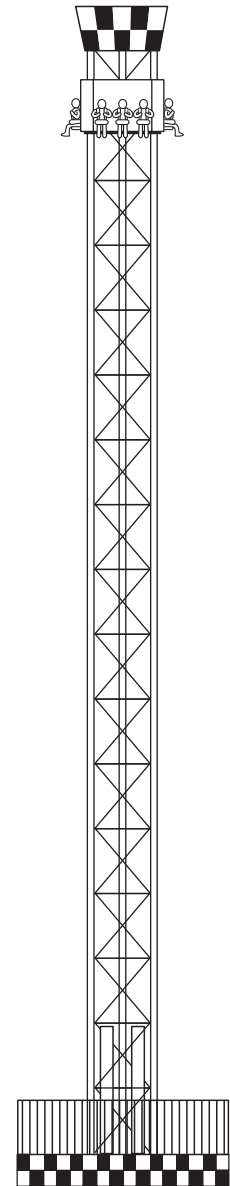

Questions

- 1 Draw a graph of height (vertical axis) vs. time (horizontal axis), using the data from your Data Chart, on the graph at the right.

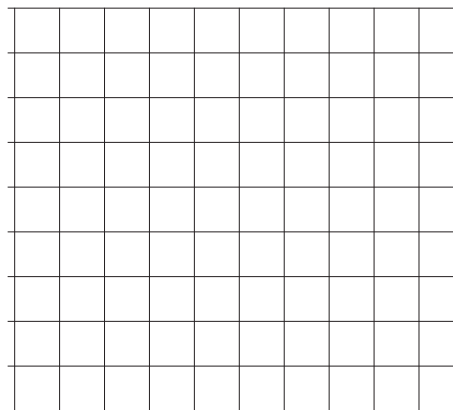

2 Describe the shape of your graph. Does it have a regular or irregular shape?

3 What does it mean when your graph shows a horizontal line?

4 What does it mean when your graph shows a line that it moving upward?

5 What does it mean when your graph shows a line that is moving downward?

Bonus Question

What does the slope of the line on your graph tell you about the motion of the ride?

Nutrition at the Amusement Park

Instructions

Observe the food stalls and their contents closely (you may even want to purchase some “edibles”) and answer the following questions.



1 After ordering a regular-sized drink, estimate how many ml of fluid you actually receive: _____ ml

2 How much does a regular drink cost? \$ _____

3 How would this price compare to a store-bought drink?

4 What type of drink did you order?
Does the flavour differ from the canned, store-bought version? If so, how?

5 Approximately how many kernels are in a bag of popcorn?
How did you make your estimation? .

6 Estimate the mass of a bag of cotton candy.

7 What are the ingredients listed on a bag of cotton candy? What do you think “certified food colours” are? What different colours does cotton candy come in? What other colours would sell well?

8 What foods did you consume at Playland?

9 What would you buy at Playland if:

(a) you were on a restricted calorie diet?

(b) you were on a low-salt diet?

(c) you were diabetic?

10 If you had the opportunity to operate a nutritious food stall at Playland, list several foods that you would sell.

11 If there was one question you could ask the “food experts” at Playland, what would it be?

12 If you had an opportunity to make one suggestion to the “food experts” at Playland, what would it be?

13 How much does a Playland hot dog cost? \$ _____
Estimate how much you think the same size hot dog would cost to make at home.

First Nations Science

We are taught and learn a Euro-centric view of science. That makes sense because in North America we were settled mainly by Europeans. But there are other points of view that are often overlooked. In this activity you will be given a chance to explore other points of view and contributions to science by other cultures. To make it easier we will divide it into sections: *transportation, housing, food and agriculture*, and others like *astronomy, medicine, fishing, sustainability*, and *environment*. So, here we go...



Transportation

There are many surfaces we have to travel over: rivers, oceans, lakes, land, mountains, etc. Start with water. Two ways to travel on water are rowboat and canoe. Compare them. Research their use and development. Which is better for Canadian rivers, lakes, rapids, northern waters and oceans? Be prepared to present your findings to your class.



Next look at land travel. What are ways to move over land, including both flat land and mountains? Again be prepared to present your findings to your class.

Food and Agriculture

The origin of the foods we eat come from many places. Select a food and research it. Focus on its origin and importance to our diet. Which foods have a First Nations origin and which came from other countries?

Astronomy

When humans developed into a farming society, it became important to know the yearly cycle and the seasons. There are examples of this around the world, from Stonehenge in England to structures in Mexico like Tulum and Chichen Itza. There are also several First Nations examples. For this topic, research one example of how we measure a year. Look at both past examples and modern ones.

Another thing people have done is look at the stars. They notice shapes of images that some stars seem to make, called constellations. Research one constellation. Draw a picture of the image made by the stars and write about the legend or story that goes with it. Do the First Nations people have a different name and story? Is the name or story different in another country? Finally, draw your own constellation of 3 to 5 stars. Draw the image they make and write a story about the image. Be prepared to tell the class what you learned.

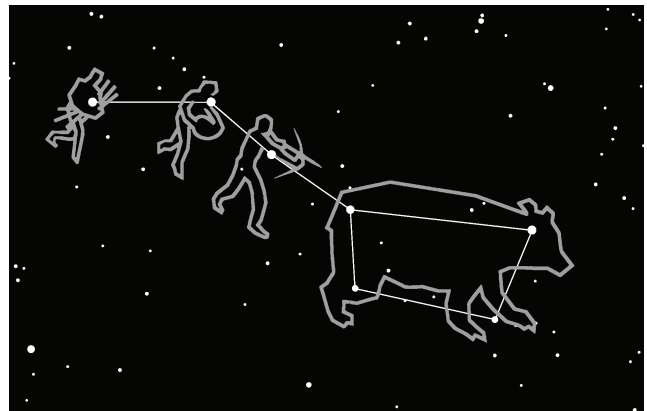

Medicine

Medicines and health remedies come from many places. For this topic, research the history of one medicine. Be prepared to present your findings to the class. Which medicines have a First Nations origin?

Fishing

Besides plants, fish have long been a part of the human diet. Research one kind of food fish. Where does it live and how is it caught? Are these methods sustainable? Finally, has the fish been important for First Nations?

Summary

Write three things you have learned in this activity that you didn't know before. What is one question you still have about First Nations science? How could you answer your question? Be prepared to share this with the class.

